



Sovella[®]
HUMAN WORKSPACE

Product catalogue 2008-2009











Sovella holds SFS-EN ISO 9001-2000 quality certification. All of our steel products have a five-year warranty. We comply with all applicable general regulations and apply industry-standard warranty conditions. We reserve the right to make changes without prior notice.

You can find our local sales network's outlet in your area from the following address: www.sovella.com.

For more information, please contact marketing@sovella.com.

Table of contents



Sovella – human workspace Colours, ESD protection, locks	2-7	
Worktables and flow-through shelving	8-29	
Accessories	30-43	
Chairs	44-45	
Drawer units	46-65	
Trolleys	66-73	
Industrial shelving and cabinets	74-85	
Perforated panels	86-93	
Assembly solutions	94-95	
Wall shelving	96-99	
Spare parts	100-101	
Index	102-103	



For all major industrial sectors

Sovella is one of the leading manufacturers of industrial workstations and furniture. We provide tailored physical infrastructure for major industry sectors all over the world.

- **Assembly industry**

Electronics, telecommunications, and fine mechanics

- **Basic industry**

Metal, engineering, and vehicle industry

- **Other industry sectors**

R&D centers and industrial laboratories
Aviation and military industry

- **Homes and public buildings**

All our products are manufactured in our modern facility in Jyväskylä, Finland.

Sovella® introduces the human factor to the workspace.

Industry evolves

Globalization brings customers and competitors nearer, and increases competition. Companies migrate to new cities and even abroad to decrease production costs and to get closer to their market. They also desire to improve productivity through people – utilizing various indicators and studies. Additionally, production processes change at an ever increasing pace, which forces factories to change their layout far more frequently than before.

Human-centered design

Sovella® workstations bring the human factor into your workspace. In their design, we have paid special attention to human physiology and individual needs. Proper ergonomics increase comfort and reduce the number of sick days, which leads to higher productivity and substantial cost savings. Our compact solutions also save floor space.

Our workstations are easy to adjust, and each detail embodies practical thinking. Thus all the equipment required for work processes is always comfortably within reach. This optimizes the operator's movements, making work less strenuous and eliminating stress injuries.

Sovella helps you evolve with your industry

We are an industrial innovator in workspace development and the customer is always our first priority. We have unique expertise in manufacturing ergonomic workspace solutions for constantly changing industrial environments. Our human workspaces increase your productivity by improving the wellbeing of your personnel. Our versatile furniture is easy to modify and update because our whole product range is modular and interchangeable.



We proactively define the future of individual workspaces, integrating our customers' needs as the cornerstones of our design process.



Tailored to suit your needs

We carefully study your workplace and production methods to ensure that you get the best possible workspace solution for your working environment and your workers' unique needs. The modular design enables you to integrate our workspaces fully with your current layout. You can also easily modify them using our wide range of interchangeable accessories.

Quality improves usability

Sovella® furniture represents high quality and real usability. Sturdy, practical structure, detailed finishing, and stylish looks are the ingredients that make up our top-class product. Ideal materials and careful testing ensure that our solutions work smoothly and are longlasting, even with constant maximum load.

Extensive product range

Each working environment has its own special requirements. We offer a wide range of standard products and solutions for numerous industry sectors. Our large variety of interchangeable accessories ensures that you get everything you need from one place.

Sovella® product family

- Workspace and factory layout planning
- Concept development
- Workstations
- Storage solutions
- Trolleys
- Assembly lines and flow-through shelving



Decorating with colour

The working environment can also look good and be inspirational. By choosing the colours of your equipment to match your corporate colours, you can reinforce your corporate image whilst creating a pleasant working environment.

Doors, drawers and **perforated panels** all come in various colours. The combination of different colours creates an interesting effect. Colours can also act as codes or identifiers.

Sovella – human workspace



Blue (02)



Ruby red (03)



Green (04)



GWS blue (07)



Light blue (08)

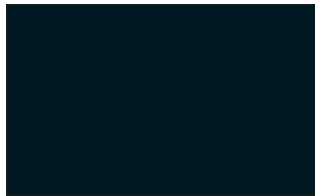

Black (18)



White (21)



Sovella red (25)



Antique copper (31)

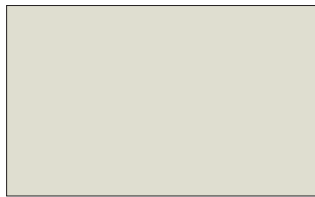

Light grey (35 & 41)



Effect silver grey (38)

Printed colours do not give a fully accurate representation of painted colours. Please ask our agent about various samples.

Colour codes

		Colour reference	Doors	Drawers	Perforated panels and back panels	System shelves
Blue	02	NCS 4040	A	A	A	-
Ruby red	03	RAL 3003	A	A	A	-
Green	04	RAL 6011	A	A	A	-
GWS blue	07	RAL 5007	STD	A/STD	STD	-
Light blue	08	RAL 5012	A	A	A	-
Black	18	RAL 9005	A	A	A	A
White	21	RAL 9010	A	A	A	STD
Sovella red	25	RAL 3002	A	A	A	A
Antique copper	31	-	-	-	-	A
Light grey	35* & 41	RAL 7035	A	A/STD	A/STD	A
Effect silver grey	38	AE 4148	A	A	A	STD

* 35 is ESD protected light grey; 41 is non-ESD protected. Please remember that ESD protection will result in a slightly darker shade of colour than the given RAL code.

STD = Standard factory colour, normal warehouse delivery, listed price

A = Factory colour, delivery 15 days from the factory, listed price

Table, cabinet, shelving and drawer frames are light grey (RAL 7035 ESD), excluding the blue drawer unit 71 (RAL 5007). Outside of the colour range, additional colours are available on request. Please contact our agents or email us at: salesupport@sovella.com.



The colour code is included in the order number. It is either at the end, following the hyphen (e.g. 860 804-**35**), or in the middle (e.g. 100/40/200 C 334 **07** 000).



ESD protection guarantees a safe working environment

Particularly in the electronics industry, work is often carried out in an EPA area that is protected from static discharge. Protection in this case means effective grounding, which involves both grounding equipment and painting the frame of the ESD workstation with semi-conductive paint.

We have extensive experience in developing, manufacturing and supplying ESD furnishings. All

our workstations and related products are supplied with an electrically semi-conducting coat of paint and we supply furnishings, seats and grounding components for ESD-protected workstations. We also build complete production systems equipped with ESD-protection. Our products meet the requirements specified in the IEC-61340-5-1 standard.

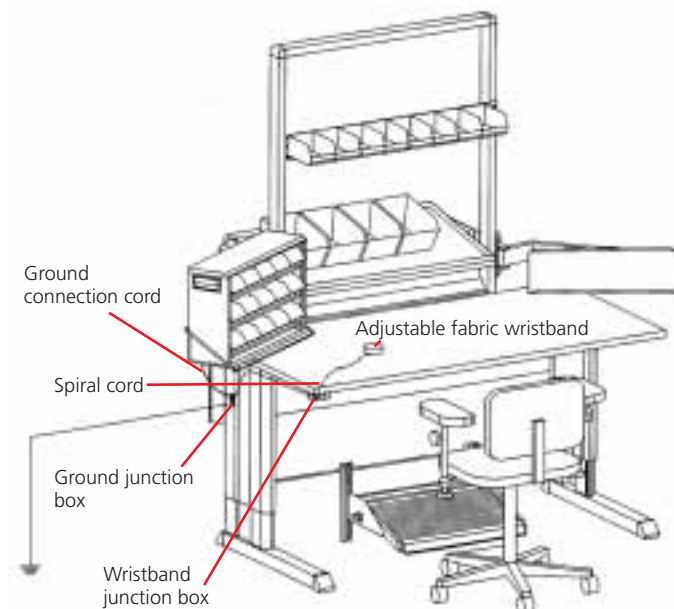

Static electricity

The abbreviation ESD stands for Electrostatic Discharge, a process that occurs between two objects of differing electric potential. Normally, electric charges are discharged slowly from objects' surfaces. If, however, the difference in electric potential becomes too great the electrical current accelerates resulting in a sudden current surge.

An ESD protected area is called an EPA area. In an EPA area, ESD protection must be observed in all materials, employees' clothing and air humidity. Workstations and employees in an EPA area must also be grounded with protective resistance (1 Mohm) to an ESD ground.

Our standards comply with the highest certification requirements

All our steel products have a 5-year warranty. To obtain a copy of our certificates, please contact marketing@sovella.com.

IPA Qualification Certificate

The Concept workstation is suitable for use in class 10.000 clean rooms in accordance with US Federal Standard 209E.



ESD-approval certification

Our products fulfill the basic requirements of IEC 61340-5-1.

Quality certification SFS-EN ISO 9001:2000



Laboratory environment certification by SEFA



Packaging treatment following to EU directives.



TÜV certification for Concept workstation

Three-level locking system

Sovella products can be equipped with a three-level locking system. This allows both serializations of individual and identical locks.

Contact your Sovella representative for additional information. The locking services are always specified for the order.

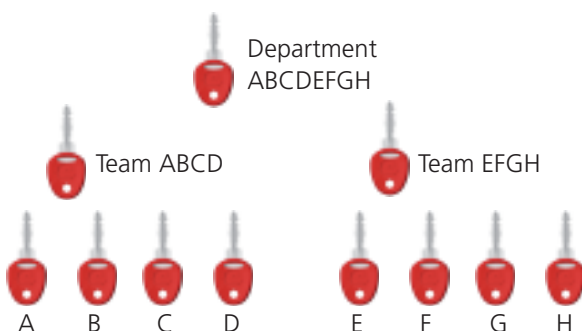

Serialization of individual locks

Each drawer or cabinet has an individual lock in a production unit, but a master key opens all the locks of the unit. The master keys can also be serialized and the third-level key opens all the drawers and cabinets of all the production units.

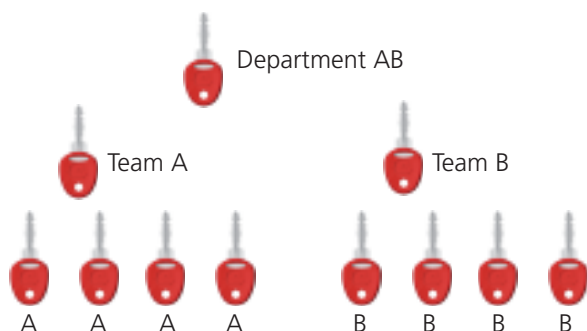

Serialization of identical locks

Each team member needs only one key to access all the drawers and cabinets in a production unit. A master key opens all the drawers and cabinets of all the production units and can also be serialized.



The worktable is the heart of the workstation

The basic element of the workstation is the worktable. Other furnishings and accessories are assembled around the table to create a well-functioning system. On these pages, we present the most important qualities of different types of worktables. Assembled systems and accessories are presented after these.

Carefully chosen materials, durability, and usability while under maximum load are common requirements for all of our worktables. The standards are often exceeded. The tables are made very ergonomic through our process of human centered design.



Accessories turn a worktable into a workstation

Equipment and components, computers, phones, and other tools can be placed ergonomically, where needed. Versatile adjustment possibilities and a wide range of accessories guarantee the ergonomics of the workstation and the flexibility of the system.



ESD protection is absolutely essential

Concept worktables are ideal for the electronics industry, where work is often done in an EPA area protected from static electricity. All tables in this range are available with ESD protection.





In the metal and automotive industries, working conditions are often demanding. Lubricants, other chemicals, heavy loads and tough conditions require robust and durable products.

Tidiness is a sign of efficiency

Necessary tools and materials must be at the worker's fingertips in order for work to be efficient. No time is lost in looking if the workstation is properly equipped for the work performed there. A tool kept in its own place stays in good condition for a long time. Sovella workspace solutions make it easy to implement lean manufacturing tools, such as 5-S (Sort-Set-Sustain-Shine-Standardize).



Good appearance is important in workshops

Modern colours and design of furnishings help to create a harmonised atmosphere. A well-designed furnishing element is practical, durable, ergonomic, and a pleasure to use.



Concept worktables

'Concept' worktables are designed for the needs of the electronics industry, where ergonomic qualities are the most important requirement. There are many possible adjustments, all components fit together seamlessly, and each detail is practical in use. The workstation adapts to the work process and the needs of the user. As a result all movements of the user can be optimised, which in turn increases performance and productivity and decreases work-related stress.

Modular design provides total integration with the existing system and the potential to flexibly adapt to changes in the environment. Concept worktables are typically used in work such as assembly, quality control, and repair.

Concept worktables are also available in motorised and hand crank versions.





Sample Concept workstations

This page shows assembled workstations that can easily be adapted to meet individual needs using the accessories on pages 30-43.



Concept worktable

Order No C 100 41 037

Incl.

qty	name	size mm	order No
1	Frame	1500 x 750	100 35 032
1	Laminate table top	1500 x 750	860 029-66



Concept motor table

Order No C 103 41 037

Incl.

qty	name	size mm	order No
1	Frame	1500 x 750	103 35 032
1	Laminate table top	1500 x 750	860 029-66



Concept crank table

Order No C 101 41 037

Incl.

qty	name	size mm	order No
1	Frame	1500 x 750	101 35 032
1	Laminate table top	1500 x 750	860 029-66



Concept workstation

Order No C 100 41 107

Incl.

qty	name	size mm	order No
1	Frame	1500 x 750	100 35 032
1	Laminate table top	1500 x 750	860 029-66
1	Upright module	2 x M750	903 35 001
1	Drawer unit 35/22	350 x 450 x 220	860 054-35
1	Fixing set		860 930-35
1	Bar Concept	1500	860 088-35
1	Footrest, bar	550 x 350	860 136-35
1	Light/balancer rail	2 x M750	918 35 006
1	Light 1000		861 862-00
2	Adjustable shelf	720 x 505	920 41 005
2	Perforated back panel	718 x 389	860 258-35
1	LCD-holder		930 35 002
1	Energy rail	440	910 51 001
2	Suspension rail	M750	846 450-35
14	Plastic container		851 623-00

Easy height adjustment

The Concept worktable can be equipped with manual or electrical height adjustment.





Worktables

Three easy steps to design your Concept workstation:

1. Select the table frame and the height adjustment method: standard, hand crank or motor table.
2. Select a table top to suit the frame: laminate or ESD table top.
3. Equip with accessories from page 30 onwards.



1. Concept worktable frame

worktable frame size W x D mm	standard table frame order No	table frame max load kg	table frame with handcrank height adjustment order No	table frame max load kg	table frame with motor height adjustment order No	table frame max load kg
1000 x 600	100 35 015	200	101 35 015	200	103 35 015	300
1000 x 750	100 35 030	500	101 35 030	200	103 35 030	300
1200 x 600	100 35 016	200	101 35 016	200	103 35 016	300
1200 x 750	100 35 031	500	101 35 031	200	103 35 031	300
1500 x 600	100 35 017	200	101 35 017	200	103 35 017	300
1500 x 750	100 35 032	500	101 35 032	200	103 35 032	300
1800 x 600	100 35 018	200	101 35 018	200	103 35 018	300
1800 x 750	100 35 033	500	101 35 033	200	103 35 033	300
2000 x 600	100 35 019	200			103 35 019	300
2000 x 750	100 35 034	500			103 35 034	300
Table height steplessly adjustable	670-1120 mm		675-1025 mm		700-1100 mm	

2. Concept corner table frame (right)

name	size W x D mm	order No
Corner table frame for a standard table 600 mm deep	1000 x 600	111 35 001
Corner table frame for a standard table 750 mm deep	1200 x 600	111 35 002

3. Concept extension table frame (right)

name	size W x D mm	order No
Extension table frame	1500 x 600	112 35 001
Extension table frame	1500 x 750	112 35 002
Extension table frame	1806 x 750	112 35 003

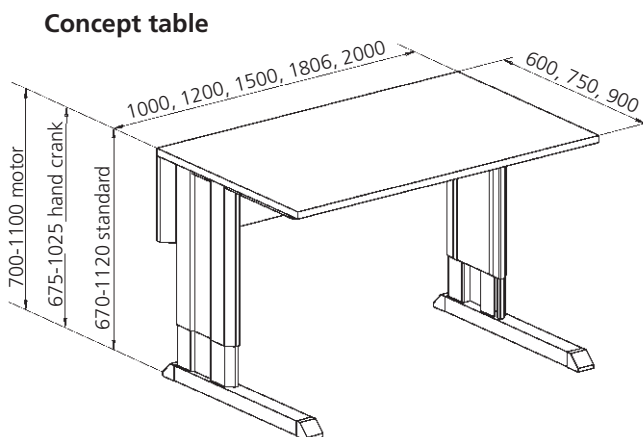

The W x D x H rule

All our dimensions follow a WDH rule, where the first dimension is the width (W), the middle the depth (D), and the last the height (H).



Table tops

Two standard choices for tops.

Table tops

size W x D mm	order No laminate table top	order No ESD table top
1000 x 600	860 026-66	860 476-63
1000 x 750	860 590-66	860 590-63
1000 x 900	860 593-66	860 593-63
1200 x 600	860 027-66	860 477-63
1200 x 750	860 554-66	860 555-63
1200 x 900	860 594-66	860 594-63
1500 x 600	860 028-66	860 478-63
1500 x 750	860 029-66	860 479-63
1500 x 900	860 031-66	860 481-63
1806 x 600	860 580-66	860 581-63
1806 x 750	860 030-66	860 480-63
1806 x 900	860 032-66	860 482-63
2000 x 600	860 591-66	860 591-63
2000 x 750	860 592-66	860 592-63
2000 x 900	860 033-66	860 483-63

750 mm deep frames are used with 900 mm deep table tops.



Laminate table top -66

Light-grey, speckled laminate surface
Plastic edges
Thickness of 23.5 mm
Threaded bushings for fixing to frames



ESD table top -63

Grey laminate surface
Beech edges
Thickness of 25 mm
Threaded bushings for fixing to frames
Semi-conductive (ESD)

The extension part 860 634-35 can be used with 900 mm deep table tops to ensure stability when handling objects heavier than 50 kg the table. It is fixed between table legs and rear case.

Colour stripes

You can add colour to the sides of Concept and TowerLine table legs with plastic stickers. There are four standard colours: blue, green, red and yellow. Colour stripes are not included in the table frame packs.

Concept table colour stripe pair

name	size mm	order No	colour
Colour stripe pair	530 x 80	860 850-00	green
Colour stripe pair	530 x 80	860 851-00	red
Colour stripe pair	530 x 80	860 852-00	yellow
Colour stripe pair	530 x 80	860 853-00	blue



Tilting frame

A Concept worktable can be equipped with a tilting mechanism that enables installation at an angle of 0–50°. When tilted, the table's load capacity is 40 kg. The tilting frame includes a table top front stop to prevent items sliding off. The tilting frame has to be installed with the bar to install the motorized mechanism.

Tilting frame 1500

name	order No
Motorized tilting frame for the Concept table	922 35 005
Bar Concept table 1500	860 088-35

The tilting frame is not available for Concept motor table.



The tilting frame is installed on the Concept worktable frame and sold separately.

Help with moving

With a transport skate, one person can easily move tables.
For long-distance moving, you will need two transport skates.

Transport skate

Compatible with tables with a max depth of 750 mm.

name	max load kg	order No
Transport skate	180	854 061-41
Transport skate ESD	180	854 061-35





Basic worktables

'Basic' worktables are standard tables that are suitable for a broad range of tasks and environments when fitted with accessories: testing, packing, repairing, inspecting. The Basic table is guaranteed for regular use with weights up to 300 kg. This degree of robustness is achieved by using a solid table structure.

The Basic upright table is ideal for lighter use, when some additional workspace is needed. The table top has smaller dimensions but the tube frame allows for the use of different accessories.



Stepless height adjustment

The height of worktables in our Basic range can be steplessly adjusted from 650 to 900 mm, which makes these tables suitable for work while sitting or standing. Packing is a typical example of work where the worktable height must be set correctly for the height of the worker.





Basic workstation examples

This page illustrate assembled workstations that are easy to adapt for individual needs through the use of accessories on pages 30-43.



Basic worktable

Order No C 120 41 105

Incl.

qty	name	size mm	order No
1	Frame	1500 x 750	120 35 022
1	Laminate table top	1500 x 750	860 029-66



Basic workstation

Order No C 120 41 101

Incl.

qty	name	size mm	order No
1	Frame	1500 x 750	120 35 022
1	Laminate table top	1500 x 750	860 029-66
3	Upright	30 x 60 x 790	860 142-35
1	Upper shelf	1500 x 370	924 41 003
1	Lower shelf	1500 x 370	924 41 008
2	Perforated back panel	718 x 389	860 258-35
1	Fixing set uprights		852 581-35

The Basic table can be equipped with wheels!

See page 103 for wheels.



Basic upright frame with table top

Order No C 123 35 102

Incl.

qty	name	size mm	order No
1	Frame	M900 x 1850	123 35 008
1	ESD table top	1200 x 600	860 477-63
1	Bracket pair		860 139-35



Basic packaging workstation

Order No C 120 41 103

Incl.

qty	name	size mm	order No
1	Frame	1800 x 900	120 35 038
1	Laminate table top	1806 x 900	860 032-66
2	Upright	30 x 60 x 1359	860 024-35
1	Upper shelf	1806 x 370	924 41 005
3	Divider	285 x 190	010 004-35
1	Cutting unit		852 606-00
1	Support tube brackets / fixing to uprights		852 605-35
1	Support tube brackets / under table top		852 604-35
1	Fixing set uprights		852 581-35
2	Round tube packing		852 603-51



Worktables

Three easy steps to design your own Basic workstation:

1. Select the table frame: Basic worktable or Basic upright table.
2. Select a table top to suit the frame.
3. Equip with accessories from pages 30-43.



1. Basic worktable frame

table frame size W x D mm	max load kg	order No
1200 x 750	300	120 35 021
1500 x 750	300	120 35 022
1500 x 900	300	120 35 037
1800 x 750	300	120 35 023
1800 x 900	300	120 35 038

The height is steplessly adjustable from 650 to 900 mm.

Basic upright frame

size W x H mm	max load	order No
M750 x 1500	100	123 35 005
M750 x 1850	100	123 35 006
M900 x 1500	100	123 35 007
M900 x 1850	100	123 35 008

Table top & brackets for Basic upright frame

size W x H mm	table top max load kg	order No laminate table top	order No ESD table top
1200 x 600	60	860 027-66	860 477-63
Bracket pair		860 139-35	

The Basic table frame has module sized spacing between mounting locations for the upright tubes.

2. Basic extension table frame (left)

table frame size W x D mm	max load kg	order No
1000 x 750	300	122 35 020
1500 x 750	300	122 35 022
1500 x 900	300	122 35 037

3. Basic corner table frame

table frame size W x D mm	max load kg	order No
1000 x 600	300	121 35 005



Lower shelves for the Basic table

name	size W x D mm	max load kg	order No
Lower shelf	1500 x 370	50	924 41 008
Lower shelf	1806 x 370	50	924 41 009

The lower shelves include a backstop.



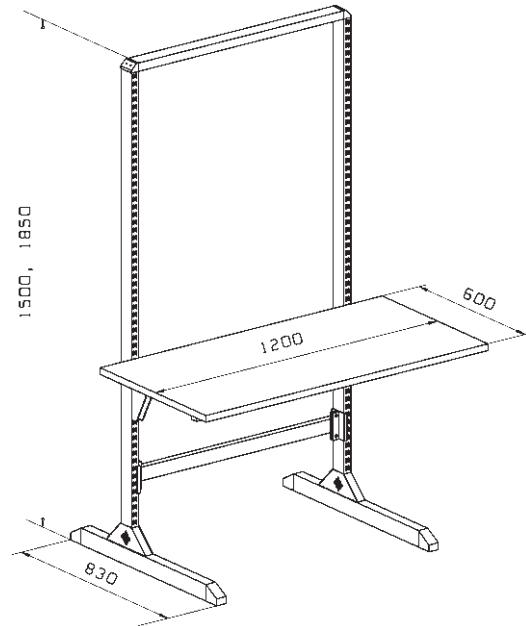
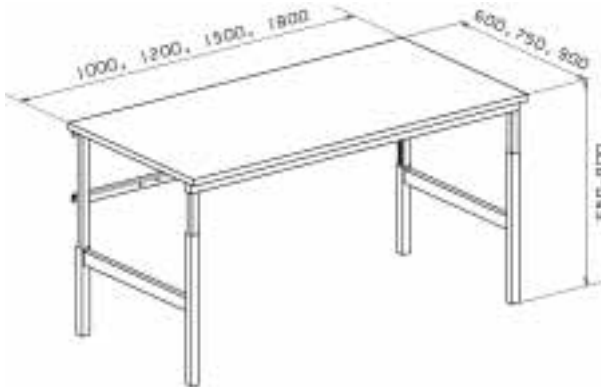

Table tops

size W x D mm	order No laminare table top	order No ESD table top
1000 x 600	860 026-66	860 476-63
1000 x 750	860 590-66	860 590-63
1000 x 900	860 593-66	860 593-63
1200 x 600	860 027-66	860 477-63
1200 x 750	860 554-66	860 555-63
1200 x 900	860 594-66	860 594-63
1500 x 600	860 028-66	860 478-63
1500 x 750	860 029-66	860 479-63
1500 x 900	860 031-66	860 481-63
1806 x 600	860 580-66	860 581-63
1806 x 750	860 030-66	860 480-63
1806 x 900	860 032-66	860 482-63
2000 x 600	860 591-66	860 591-63
2000 x 750	860 592-66	860 592-63
2000 x 900	860 033-66	860 483-63



Laminare table top -66

Light-grey, speckled laminare surface
Plastic edges
Thickness of 23.5 mm

Modular size

The modular (M) size refers to the distance between two upright tubes from the middle of the tube.

The modular size is used to find the appropriate accessories.

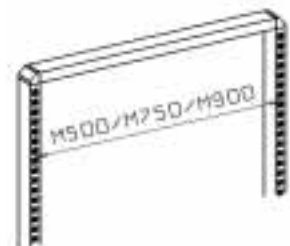



Worktables

Workshop worktables

'Workshop' worktables are designed for the most demanding use and environments. Mechanical workshops, garages, and heavy industry are environments where chemicals, heavy loads, and strenuous use necessitate robustness. These worktables are very durable and withstand the

toughest conditions. There is a wide range of accessories available.

The Workshop table is guaranteed for regular use with loads up to 750 kg.



A drawer unit can serve as a leg

Workshop worktables can be easily extended by using a drawer frame or a leg as a common support for two worktables.

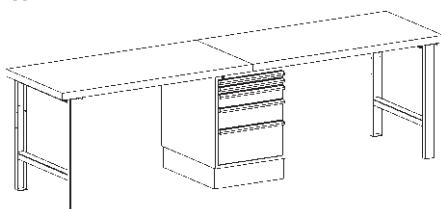

This example includes

qty	name	size mm	order No
2	Fixed leg		836 303-35
2	Steel table top	1500 x 750	836 721-74
1	Drawer unit 55/66-5	550 x 715 x 800	612 07 205



Workshop workstation examples

This page illustrates assembled workstations that are easy to adapt for individual needs through the use of accessories on pages 30-43.



Workshop standard worktable

Order No C 130 41 101

Incl.

qty	name	size mm	order No
2	Adjustable leg		836 664-35
1	Steel table top	1500 x 750	836 721-74
1	Spacer bar	1500-2250	836 451-35



Workshop repair workstation

Order No C 130 41 213

Incl.

qty	name	size mm	order No
2	Fixed leg		836 303-35
1	Steel table top	1500 x 750	836 721-74
3	Upright tube	30 x 60 x 996	860 367-35
2	Perforated panel	736 x 640	835 633-07
1	Drawer unit 55/37-1	550 x 715 x 370	611 07 001
1	Fixing frame		860 375-35



Workshop installation workstation

Order No C 130 41 110

Incl.

qty	name	size mm	order No
2	Fixed leg		836 303-35
1	Steel table top	1500 x 750	836 721-74
1	Lower shelf	1370 x 648	924 35 012
1	Drawer unit 55/13-1	550 x 715 x 130	610 07 001
1	Spacer bar	1500-2250	836 451-35



Workshop workstation

Order No C130 41 116

Incl.

qty	name	size mm	order No
1	Steel table top	1500 x 750	836 721-74
1	Adjustable leg	700-950	836 664-35
1	Fixing frame	1500	860 375-35
3	Upright tube	1359	860 024-35
1	Light/balancer rail	2 x M750	918 35 006
1	Light 1000		861 862-00
1	Energy rail	440	910 51 001
2	Steel shelf	M750 x 300	836 028-35
2	Suspension rail	M750	846 450-35
5	Plastic container		851 622-00
7	Plastic container		851 623-00
1	Perforated tool cabinet	M750	852 629-07
1	Drawer unit 55/66		612 07 204



Worktables

Four easy steps to create your Workshop workstation:

1. Select the appropriate table top: steel or plastic.
2. Select a support for both ends of the table top: adjustable or fixed leg or a drawer unit.
3. Use a spacer bar to stabilise the table. A fixing frame can be used instead of a spacer bar if upright tubes are used.
4. Equip with accessories from pages 30-43.

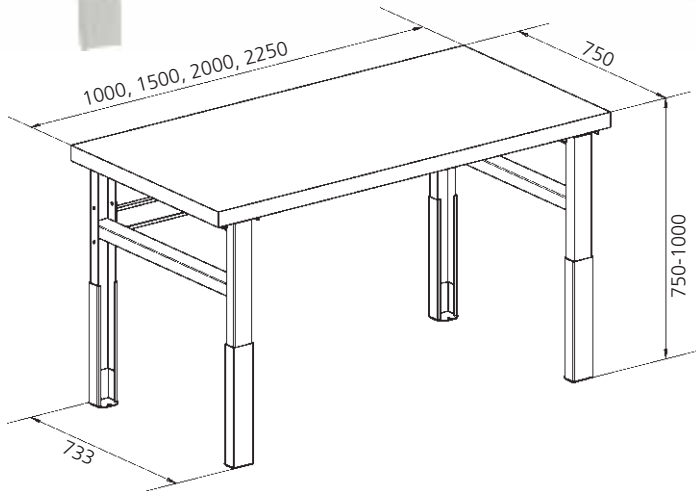

Workshop legs

name	height mm*	order No
Adjustable leg	700-950	836 664-35
Fixed leg	800	836 303-35

* Height excluding top.

Spacer bar

width mm	order No
1000-1500	852 694-35
1500-2250	836 451-35

Fixing frame

Fixing frame is needed if the table is equipped with upright tubes. Replaces the spacer bar. Module spacing between mounting locations.

width mm	order No
1000	852 693-35
1500	860 375-35
2000	860 725-35
2250	860 376-35

The W x D x H rule

All our dimensions follow a WDH rule, where the first dimension is the width (W), the middle the depth (D), and the last the height (H).



The Workshop table can be fitted with a lower shelf for bulky items.

Lower shelves for the Workshop table

name	size W x D mm	max load kg	order No
Lower shelf for adjustable leg for table 1500	1370 x 648	200	924 35 012
Lower shelf for fixed leg for table 1500	1370 x 648	200	924 35 014
Lower shelf for adjustable leg for table 2000	1870 x 648	100	924 35 013
Lower shelf for fixed leg for table 2000	1870 x 648	100	924 35 015
Lower shelf for adjustable leg for table 2250	2120 x 648	100	924 35 016
Lower shelf for fixed leg for table 2250	2120 x 648	100	924 35 018

The lower shelves include a backstop.





Workshop table tops



Workshop steel top -74

Steel top 1.5 mm
 Spray-painted dark-grey surface
 Blue plastic end edges
 Plywood and chipboard core
 Threaded bushings for fixing legs and drawer units
 3 mm steel top available on request
 Thickness of 50 mm



Workshop top with steel edges

Plastic top
 Grey plastic surface
 Galvanized steel moulding in the front edge
 Plywood and chipboard core
 Threaded bushings for fixing legs and drawer units
 Thickness of 50 mm

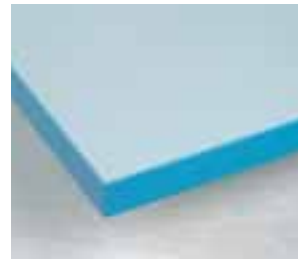

Workshop top with plastic edges

Plastic top
 Grey plastic surface
 Blue plastic throughout edges
 Plywood and chipboard core
 Threaded bushings for fixing legs and drawer units
 Thickness of 50 mm



Workshop wooden top

Birch plywood on top and bottom
 Strong sandwich structure
 Chipboard core
 Threaded bushings for fixing to legs and drawer units
 Thickness of 50 mm

Workshop table tops

table top size W x D mm	steel top 1,5 mm	max load kg	plastic top with steel edges	max load kg	steel top 3 mm	max load kg	plastic top with plastic edges	max load kg	wood top	max load kg
1000 x 750	836 720-74	750	836 723-79	750						
1500 x 750	836 721-74	750	836 724-79	750	852 653-74*	750	836 726-79*	500	836 721-88	500
2000 x 750	836 736-74*	500							836 736-88	500
2250 x 750	836 722-74	500	836 725-79	500	852 649-74*	750	836 727-79*	500		

* Non-stock item



Structure of the table top

For us, the table top is an important part of a table's structure. For example, the Workshop table top is designed for very heavy loads. Because of the table top's structure, the table is very sturdy, even with the highest loads. The feet and the drawers are attached to the threaded bushings in the table tops.





TowerLine worktables

'TowerLine' worktables are a solution suitable for a modern, state-of-the-art laboratory. They are designed to accommodate the necessary measurement equipment and other tools ergonomically at a safe distance for use. The TowerLine worktables are robust, elegant, and very flexible; they adapt to individual needs, new equipment, and changes in environment or work.

The flexibility and ergonomics of industrial workstations are now also available for development and research laboratories. TowerLine tables provide more space for R&D and measuring work. Space can be used more effectively with double-sided workstations. This also means that the same equipment can be used for an entire team.





TowerLine workstation examples

This page illustrate assembled workstations that are easy to adapt for individual needs through the use of accessories on pages 30-43.



TowerLine single-sided workstation

Order No C 125 41 105

Incl.

qty	name	size mm	order No
1	Frame	M1500 x 835	125 35 004
1	Laminate table top	1570 x 835	854 466-66

The colour strips are not included in the combination.



TowerLine double-sided workstation

Order No C 125 41 106

Incl.

qty	name	size mm	order No
1	Frame	M1500 x 1500	125 35 008
1	Laminate table top	1570 x 1500	854 611-66
4	Steel shelf	M1500 x 300	854 481-35

The colour strips are not included in the combination.



TowerLine workstation for teamwork

Order No C 125 41 103

Incl.

qty	name	size mm	order No
1	Frame	M1500 x 1500	125 35 008
1	Extension frame	M1500 x 1500	125 35 018
2	Laminate table top	1570 x 1500	854 611-66
8	Steel shelf	M1500 x 300	854 481-35
4	Light/balancer rail	2 x M750	918 35 006

The lights and the colour strips are not included in the combination.





Worktables

Three easy steps to design your own TowerLine workstation:

1. Select a single-sided or double-sided frame solution.
2. Select a table top to suit the frame: laminate or ESD.
3. Equip with accessories from pages 30-43.



The TowerLine table top has holes for cables.

TowerLine worktable frame

name	size	1-sided depth	1-sided order No	2-sided depth	2-sided order No
Worktable frame	M1200	835	125 35 003	1500	125 35 007
Worktable frame	M1500	835	125 35 004	1500	125 35 008
Worktable frame	M1800	835	125 35 005	1500	125 35 009

Table height is steplessly adjustable from 700 to 1120 mm.

Frame load capacity is 300 kg/section of even load, of which 200 kg on table top.

TowerLine extension frame

name	size	1-sided depth	1-sided order No	2-sided depth	2-sided order No
Extension frame	M1200	835	125 35 013	1500	125 35 017
Extension frame	M1500	835	125 35 014	1500	125 35 018
Extension frame	M1800	835	125 35 015	1500	125 35 019

TowerLine corner table frame

name	size W x D mm	order No
Corner table frame	835 x 835	125 35 011

Only suitable with one sided frame.

Steel shelves

name	module	size W x D mm	max load kg	order No
Steel shelf	M1200	1167 x 300	80	854 480-35
Steel shelf	M1200	1167 x 400	80	854 483-35
Steel shelf	M1500	1467 x 300	80	854 481-35
Steel shelf	M1500	1467 x 400	80	854 484-35
Steel shelf	M1800	1773 x 300	80	854 482-35
Steel shelf	M1800	1773 x 400	80	854 485-35
Corner shelf		1318 x 400	80	854 479-35

Cable trough in TowerLine worktable

The leg of the TowerLine table includes a cable trough which makes it easy to organise cables.



Modular size

The modular (M) size refers to the distance between two upright tubes from the middle of the tube. The modular size is used to find the appropriate accessories.

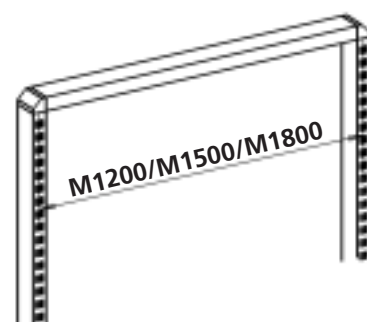

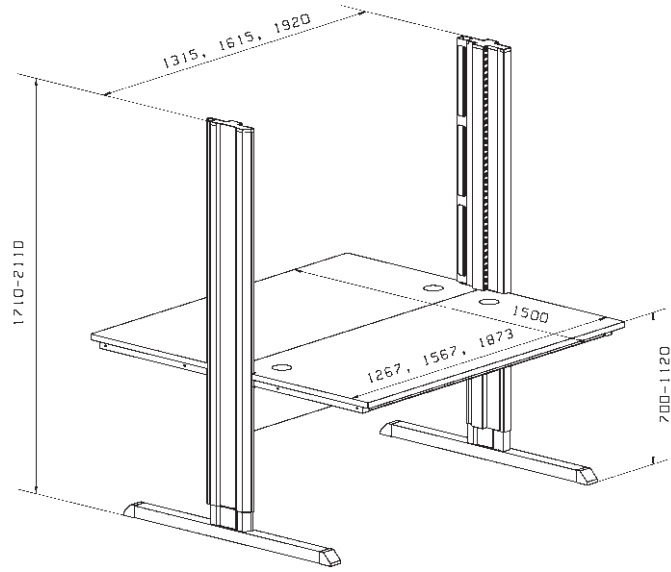
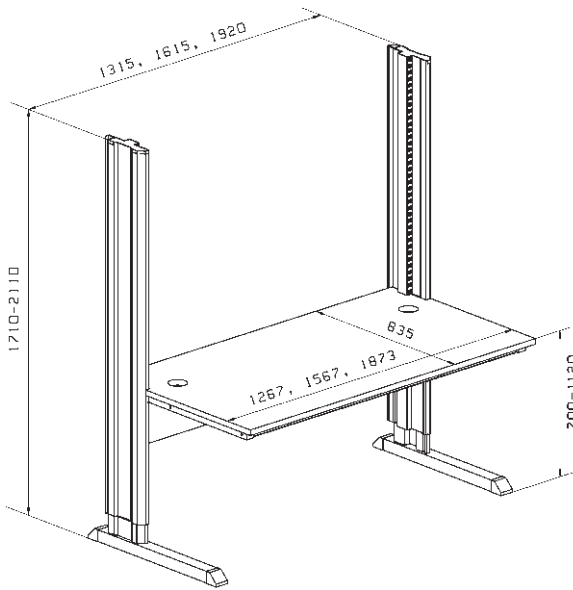

TowerLine table tops



Laminate table top -66

Light-grey, speckled laminate surface
Plastic edges
Thickness of 23.5 mm
Threaded bushings for fixing to frames



ESD table top -63

Grey laminate surface
Beech edges
Thickness of 25 mm
Threaded bushings for fixing to frames
Semi-conductive (ESD)

TowerLine table tops

name, 1-sided	table top size W x D mm	laminate top order No	ESD top order No
M1200	1270 x 835	854 465-66	854 471-63
M1500	1570 x 835	854 466-66	854 472-63
M1800	1870 x 835	854 467-66	854 473-63
Corner table top	835 x 835	854 477-66	854 478-63
name, 2-sided	table top size W x D mm	laminate top order No	ESD top order No
M1200	1270 x 1500	854 610-66	854 613-63
M1500	1570 x 1500	854 611-66	854 614-63
M1800	1870 x 1500	854 612-66	854 615-63

TowerLine arm holders

name	order No
Arm holder 40	861 098-35
Arm holder 60	861 099-35



TowerLine accessories

The TowerLine worktable foot has the same perforation as the upright tubes. Therefore the TowerLine table can be equipped with the same accessories as other Sovella tables. Use the arm holders 40 and 60 to fix the arms.



Colour stripes

You can add colour to the sides of TowerLine table legs with plastic colour stripes. There are four standard colours: blue, green, red and yellow. The colour stripes has to be ordered separately.



TowerLine table colour stripe pair

name	size mm	order No	colour
Colour stripe pair	1615 x 80	860 854-00	blue
Colour stripe pair	1615 x 80	860 855-00	green
Colour stripe pair	1615 x 80	860 856-00	red
Colour stripe pair	1615 x 80	860 857-00	yellow





FlexFlow flow-through shelving

FlexFlow flow-through shelving can be used as a standalone solution or integrated into a single workstation or assembly line, resulting in faster throughput, less WIP, higher productivity and managed inventories. Your assembly process as a whole will become simpler and more efficient.

FlexFlow is a flexible solution that allows easy addition and removal of components as the role of the workstation changes. FlexFlow can easily be customised to your application and operator using a wide range of accessories. When FlexFlow is equipped for, and adjusted to individual needs the whole production process benefits.



FlexFlow module sizes

FlexFlow is based on module sizes in order to allow it to be easily integrated with other Sovella workspace solutions and the MultiLine transfer system. The available sizes are M750 and M900. Both the width and the depth can be increased by combining standard modules that are M750 and M900 in width and 900 mm in depth.

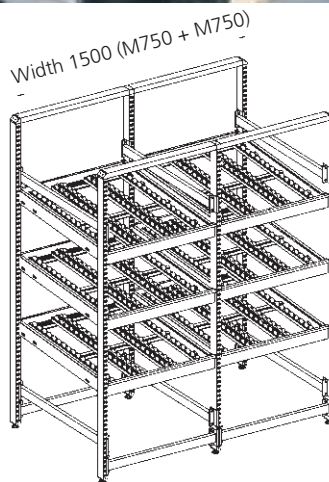



FlexFlow combinations

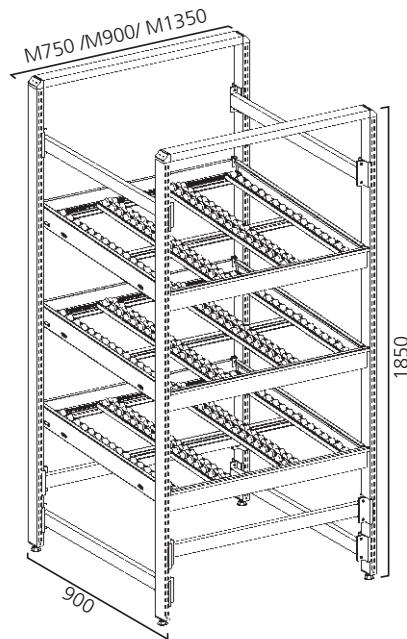

Base section

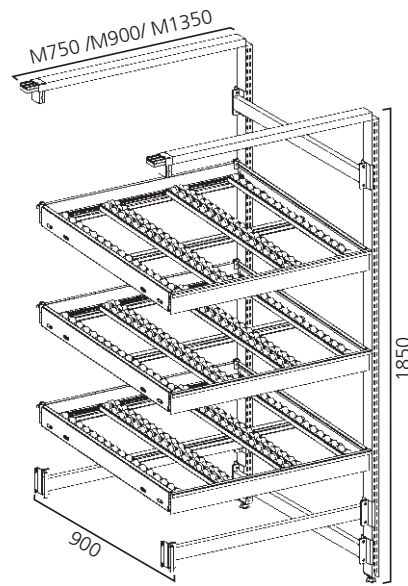

Extension section

FlexFlow base sections with 3 roller tops and 9 tracks.

name	max load kg	quantity	M750 x 900 Order No C 801 35 033		M900 x 900 Order No C 802 35 033		M1350 x 900 Order No C 803 35 033				
			module	size W x D x H mm	order No	module	size W x D x H mm	order No	module	size W x D x H mm	order No
Frame support 1850 with adjustment screw	600	4		1850	852 535-35		1850	852 535-35		1850	852 535-35
Spacer bar width		2	M750		851 483-35	M900		840 106-35	M1350		854 862-35
Spacer bar depth		4		900	852 459-35		900	852 459-35		900	852 459-35
Horizontal tube		2	M750		847 402-35	M900		840 104-35	M1350		850 914-35
Corner bracket pair		2			848 336-35			848 336-35			848 336-35
Roller top	200	3	M750	M750 x 900	852 502-35	M900	M900 x 900	852 505-35	M1350	M1350 x 900	850 902-35
Assembly rail pairs		3	M750		852 517-35	M900		852 518-35	M1350		850 909-35
Roller profile 850, without flange, ESD 3kg/roll		6		850	852 731-00		850	852 731-00		850	852 731-00
Roller profile 850, with flange, ESD 3kg/roll		12		850	852 727-00		850	852 727-00		850	852 727-00
Stopper/cover rail, unloading end		3	M750		852 515-35	M900		852 516-35	M1350		850 913-35
Stopper/cover rail, loading end		3	M750		852 525-35	M900		852 526-35	M1350		850 911-35

FlexFlow extension sections with 3 roller tops and 9 tracks.

name	max load kg	quantity	M750 x 900 Order No C 801 35 133		M900 x 900 Order No C 802 35 133		M1350 x 900 Order No C 803 35 033				
			module	size W x D x H mm	order No	module	size W x D x H mm	order No	module	size W x D x H mm	order No
Frame support 1850 with adjustment screw	600	2		1850	852 535-35		1850	852 535-35		1850	852 535-35
Spacer bar width		2	M750		851 483-35	M900		840 106-35	M1350		854 862-35
Spacer bar depth		2		900	852 459-35		900	852 459-35		900	852 459-35
Horizontal tube		2	M750		847 402-35	M900		840 104-35	M1350		850 914-35
Straight bracket		2			851 827-35			851 827-35			848 336-35
Roller top	200	3	M750	M750 x 900	852 502-35	M900	M900 x 900	852 505-35	M1350	M1350 x 900	850 902-35
Assembly rail pairs		3	M750		852 517-35	M900		852 518-35	M1350		850 909-35
Roller profile 850, without flange, ESD 3kg/roll		6		850	852 731-00		850	852 731-00		850	852 731-00
Roller profile 850, with flange, ESD 3kg/roll		12		850	852 727-00		850	852 727-00		850	852 727-00
Stopper/cover rail, unloading end		3	M750		852 515-35	M900		852 516-35	M1350		850 913-35
Stopper/cover rail, loading end		3	M750		852 525-35	M900		852 526-35	M1350		850 911-35

Roller profiles 850

name	order No
Roller profile 850, without flange	852 509-00
Roller profile 850, with flange	852 592-00



Seven steps to assemble the FlexFlow:

A. Frame 1

- Pick up the frame support legs (equipped with an adjustable screw, a wheel or a wheel with a brake). 4 pcs per base module and 2 pcs per module extension are needed.

B. Spacer bars 2-6

- Start with one frame support leg and attach one width and one depth spacer bar to it. Attach another frame support leg to the previously assembled leg with spacer bars. Continue assembling the frame in this way.
- One base frame with four support legs has four depth spacer bars, two width spacer bars and two horizontal tubes (four width spacer bars if horizontal tubes are not used). Horizontal tubes can replace the topmost width spacer bars which frees up all the space between the uprights for items. If the items on the top roller shelf are taller than the upright height, horizontal tubes cannot be used.

C. Roller top and loading/unloading shelves 7-8

- Assemble the roller tops and attach them to the assembled frame. The heights and angles of the tops should be defined here before assembly. Normally a 3 degree angle is suitable (750 mm deep shelf > 3-4 cm, 900 mm deep shelf > 4-5 cm). Shelf angles should always be checked after assembly and the angle adjusted accordingly.

- Assemble the loading/unloading shelves (if ordered) and attach them at the correct height either on the loading or unloading end. Adjust the loading/unloading shelf to the correct angle. Please note that too large a difference in the angle (> 3 degrees) between the roller top and the loading/unloading shelf may prevent the item from rolling over e.g. onto the unloading shelf.

D. Assembly rail pair 9

- The assembly rail pair is used for fixing the roller profiles. You need one assembly rail pair per roller top or per loading/unloading shelf.
- Attach the assembly rails to the ends of the roller shelves and/or the loading/unloading shelf. The rail with longer clips should be on the loading end or the higher end.
- Do not fix the assembly rail with screws if you have a stopper/cover rail at the same end.

E. Stopper/cover rails 10-11

- The stopper rail is used at the unloading end. It closes the open profile ends, strengthens the roller top and stops the item. The stopper rail is attached either to the lower end of the roller top or to the end of the unloading shelf (if ordered).
- The cover rail is used at the loading end. It closes the open profile ends and strengthens the roller top. It has a cut for feeding the items onto the rollers.

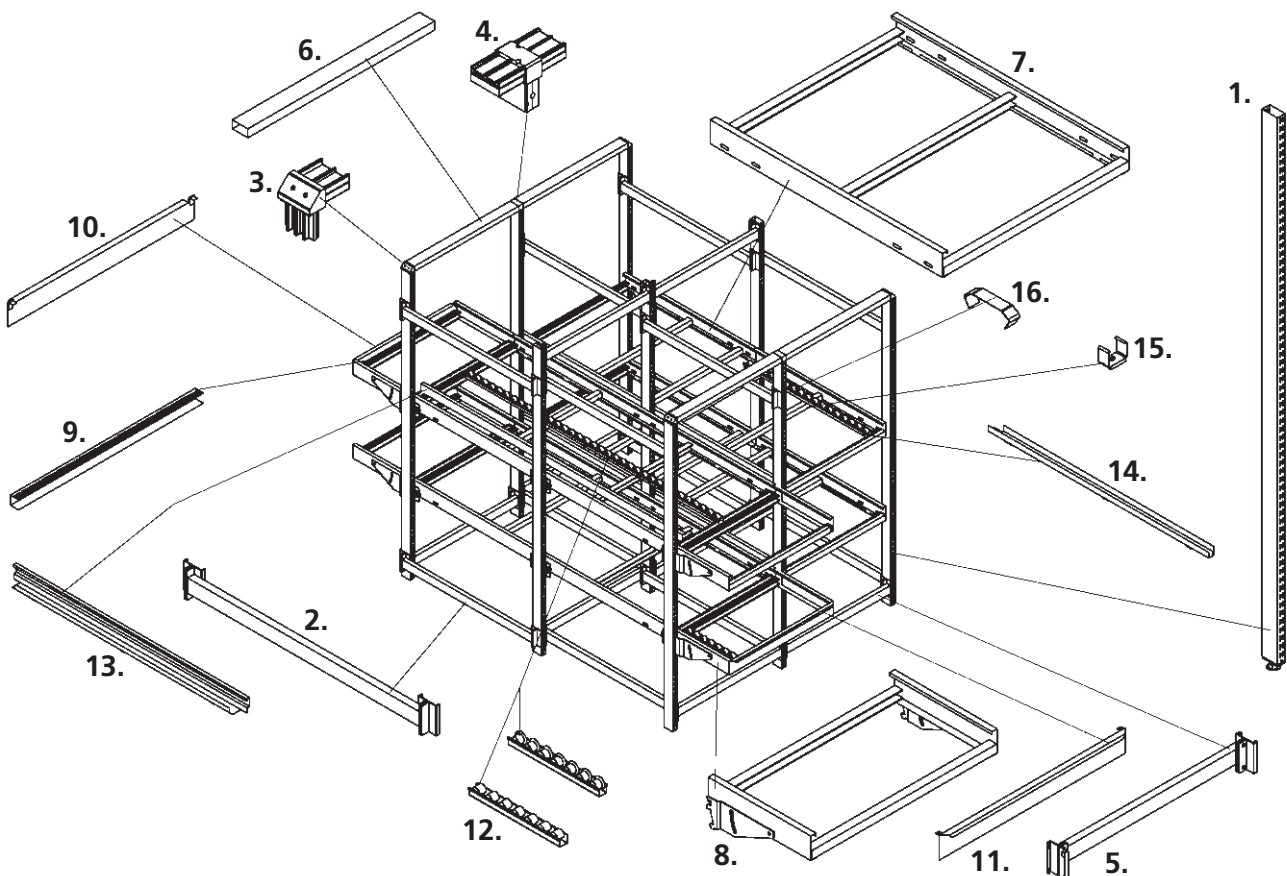



F. Roller profiles 12-13

- First stick the roller profile towards the rear assembly rail at the higher end and under the longer clips, and then pull it back and fit it under the clips of the front assembly rail.
- The side profiles of the roller top guide the item and therefore flanged roller profiles are not needed on the sides. In the middle of the roller top, you should use either flanged roller profiles to divide the two tracks, or a divider rail pair if solid guidance is needed (e.g. for cardboard boxes or other flexible products). Flexible or heavy items (> 3kg/roll) may need additional roller profiles in the middle of the track.

G. Other parts for assembly 14-16

- The spring holder is used to fix the roller profile to the lateral supporting profile of the roller top. This is designed especially for 1800 mm long roller profiles with > 1 kg load/box.

- The spring latch is used to prevent the roller profile from opening under heavy loads. Over 2 kg per roll is considered here to be a heavy load. The spring latch is an easy solution for FlexFlows in occasional use. This product is a safety device and is highly recommended!
- The U-profile is used to prevent the roller profile from opening under heavy loads. Over 2 kg per roll is considered here to be a heavy load. The U-profile is the solution recommended for FlexFlows in frequent use. This product is a safety device and is highly recommended!
- Brake for roller profiles
 - Stopper rails are not designed to stop heavy items travelling at full speed.
 - The speed of the item can be adjusted using the roller top angle. The brakes are used in FlexFlow to control the acceleration of the item. This is essential for smooth functioning.
 - Brakes are needed on most FlexFlows. They are highly recommended!

Frame supports for all FlexFlow shelving

picture No	name	size mm	order No	ESD order No
1	Frame support with adjustment screw	1850	852 535-35	
1	Frame support with wheel	1976	852 523-41	852 523-35
1	Frame support with brake wheel	1976	852 524-41	852 524-35
2	Spacer bar, depth	900		852 459-35
3	Corner bracket pair			848 336-35
4	Straight bracket			851 827-35



Components for FlexFlow

picture No	name	M750		M900		M1350	
		size	order No	size	order No	size	order No
5	Spacer bar	M750	851 483-35	M900	840 106-35	M1350	854 862-35
6	Horizontal tube	M750	847 402-35	M900	840 104-35	M1350	850 914-35
7	Roller top 900	M750 x 900	852 502-35	M900 x 900	852 505-35	M1350 x 900	850 902-35
7	Roller top 1800	M750 x 1800	852 503-35	M900 x 1800	852 506-35	M1350 x 1800	850 903-35
8	Loading/unloading shelf	M750	852 519-35	M900	852 520-35	M1350	850 907-35
9	Assembly rail pair	M750	852 517-35	M900	852 518-35	M1350	850 909-35
10	Cover rail, loading	M750	852 525-35	M900	852 526-35	M1350	850 913-35
11	Stopper/cover rail, unloading	M750	852 515-35	M900	852 516-35	M1350	850 911-35

Roller profiles

picture No	name	size mm	with flange		without flange	
			order No	ESD-order No	order No	ESD order No
12	Roller profile, loading/unloading shelf	350	852 591-00	852 726-00	852 508-00	852 730-00
12	Roller profile 900	850	852 592-00	852 727-00	852 509-00	852 731-00
12	Roller profile 1800	1750	852 593-00	852 728-00	852 510-00	852 732-00
12	Roller profile 2700	2650	852 594-00	852 729-00	852 511-00	852 733-00
12	Roller profile 3600	3550	852 722-00	852 724-00	852 723-00	852 725-00

Other parts for assembling

picture No	name	size mm	order No
13	Divider rail pair	900	852 512-35
13	Divider rail pair	1800	852 513-35
14	U-profile	900	852 578-35
14	U-profile	1800	852 579-35
15	Spring holder, roller profiles*		852 595-50
16	Brake, roller profiles		852 546-00
	Spring latch**		852 441-00

*Spring holder is used to attach the roller profile to middle cross support and thus to prevent side movement.

**When loading of roller profiles is close to maximum the spring latch stop their from "spread out".

FlexFlow workstation accessories

name	size W x D mm	max load kg	order No (ESD)
Worktop bracket pair			860 139-35
Laminated worktop	1200 x 600	60	860 027-66
ESD worktop	1200 x 600	60	860 477-63

All module sized accessories can be used also with FlexFlow, e.g. Light/balancer rails and shelves

FlexFlow workstation M1350 accessories*

name	module size	size W x D mm	max load kg	order No
Steel shelf	M1350	1340 x 300	50	860 787-35
Steel shelf	M1350	1340 x 400	50	860 788-35
Adjustable shelf	M1350	1320 x 505	100	920 35 013
Adjustable shelf	M1350	1320 x 650	100	920 35 014
Light/balancer rail	M1350	1350	15	918 35 011

* M750 and M900 accessories, see pages 33 - 43.



Accessories provide increased functionality

Optimising workstation functionality may prove difficult without well-chosen accessories that increase usability. When a workstation is well-planned and well-equipped, workflow becomes

easier and more efficient, improving ergonomics and making it easier to keep tools in place. You will find out more about our range of accessories and supplies on the following pages.



Modular means adaptable

Our world keeps changing at an ever-increasing pace. Until recently, products could be manufactured the same way for decades, but now we must prepare to make changes to our work practices at a much faster rate. In order to revise the production process to meet new requirements, an extremely flexible and adaptable workstation system is essential. Our system is designed particularly with this in mind. The same basic units, equipped with accessories that meet your needs, offer a wide range of applications.

The module size is used to identify the right accessories

In line with the modular approach of Sovella industrial furnishings, a large number of products are organised in three module sizes: M500, M750 and M900. The module size refers to the distance in mm between two upright tubes from the middle of the tube. This means that some of our accessories are organised by their modular size.

Customised for your application and your operator

The purpose of a workstation determines its basic requirements and accessories. The needs and requirements may change considerably from one employee to another, but we understand that no two people are alike. When a workstation is equipped for and adjusted to an individual's needs, each phase of the production process can be completed without delay, with accuracy and with maximum comfort.





Upright tubes and upright tube modules

Upright tubes are the basic element for accessorising Sovella industrial furnishings. Accessories are attached to Concept, Basic and Workshop tables with the aid of upright tubes

or a pre-assembled, upright tube module. The tubes or the module are attached to the back of the table. The module is extended with an upright tube, a horizontal tube and a straight bracket.

Upright tubes

name	size mm	length (l) mm	order No
Upright tube	30 x 60	500	860 991-35
Upright tube	30 x 60	790	860 142-35
Upright tube	30 x 60	996	860 367-35
Upright tube	30 x 60	1359	860 024-35
Upright tube	30 x 60	1582	860 025-35
Upright tube pair*	30 x 30	1219	854 038-35

*Used in the service trolley

Horizontal tube	M500	860 819-35
Horizontal tube	M750	847 402-35
Horizontal tube	M900	840 104-35

Corner bracket pair	848 336-35
Straight bracket	851 827-35

Aluminium bracket

name	order No
Aluminium bracket	846 554-00

Fixing set for Basic table

name	order No
Fixing set for Basic table	852 581-35

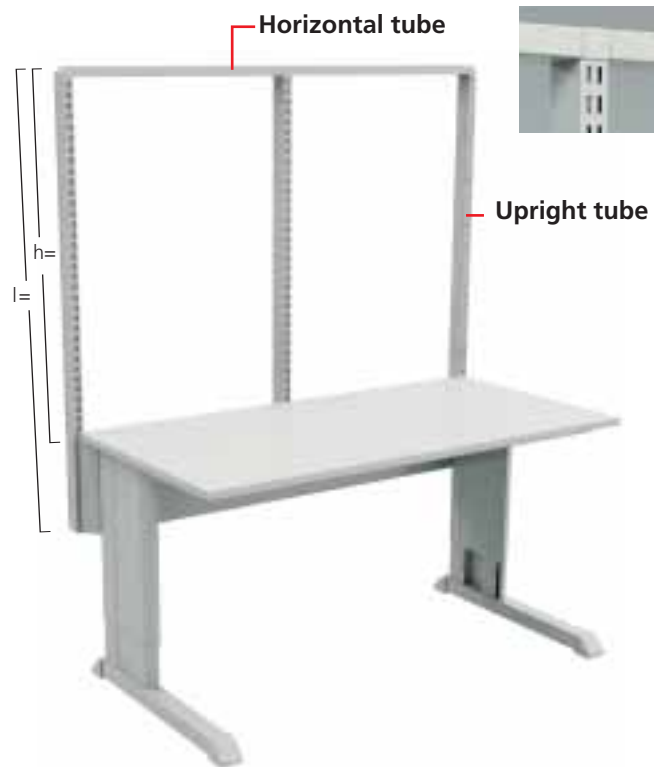

Upright modules and this compatibility

	length (l) = 1359 mm		length (l) = 1582 mm				
	h = 1075 mm	h = 1300 mm	suitable for table widths				
	order No	order No	1000	1200	1500	1800	2000
1 x M750	900 35 001	900 35 002	x	x	x	x	x
1 x M900	901 35 001	901 35 002	x	x	x	x	x
2 x M500	902 35 001	902 35 002	x	x			
2 x M750	903 35 001	903 35 002			x	x	x
2 x M900	904 35 001	904 35 002				x	x
3 x M500	905 35 001	905 35 002			x	x	x
4 x M500	906 35 001	906 35 002					x

h = module's height attached from the table top surface

Upright tube with aluminium bracket attached to the table

A separate aluminium bracket (846 554-00) can be used to attach a single tube to the table.

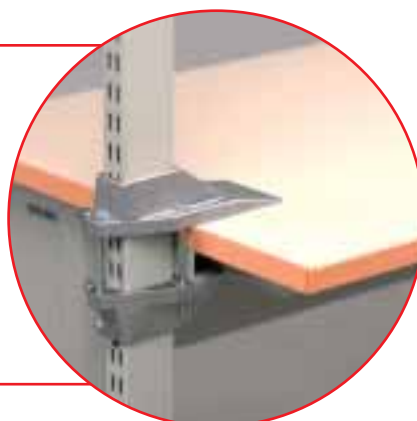

Modular size

The modular (M) size refers to the distance between two upright tubes from the middle of the tube.

The modular size is used to find the appropriate accessories.

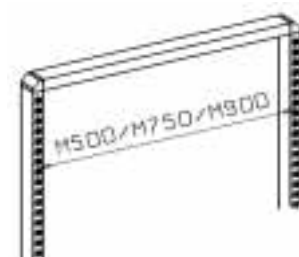



Lighting ergonomics



Good lighting is part of the company's image; a fact which is now more widely acknowledged.

Optical ergonomics requires optimised conditions

Optical ergonomics relates to optimal viewing conditions; where the work performed does not unduly stress the eyes, even when working constantly over long periods of time. This requires the viewed object, such as a piece of equipment being assembled, to be at a suitable distance and direction, in order to keep eye movements at an acceptable level and ensure that the details can be seen without problems.

Another important requirement is adequate and glare-free lighting. In particular, poor viewing conditions affect presbyopic people (on average above 45 years of age) whose closest possible viewing-point is at a distance of around 50 cm. If the employee uses reading glasses at work, the position of the viewed object and the lighting require some additional attention.

When optical ergonomics have been integrated in the environment and the working position is well adjusted, you can expect to save time and money due to fewer absences and decreased stress.

Recommended by the indoor lighting standard

When designing workstations and their respective lighting, we observe the recommendations of the EN 12464-1 standard on indoor workplace lighting. These recommendations apply mainly to the actual workstation and its immediate surroundings. The conditions set by the standard must be met in every location where the workstation could be placed. This becomes possible only with adequate, ambient lighting or quality workstation lighting, the latter often being the more cost-efficient solution.

When designing the workstation lighting, the requirements of the work are determined first. A task that demands a good eye for detail usually calls for a spotlight. If the viewed object is square, at least two luminaires are necessary, in order to remove shadows. If the viewed object is a level surface, it can be illuminated with one long fluorescent lamp – though it is important to remember to direct any reflections away from the employee.

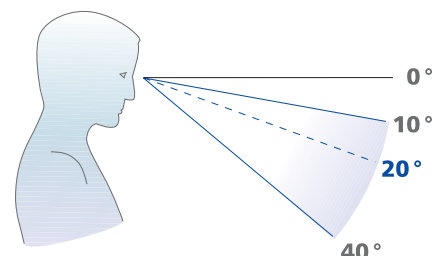
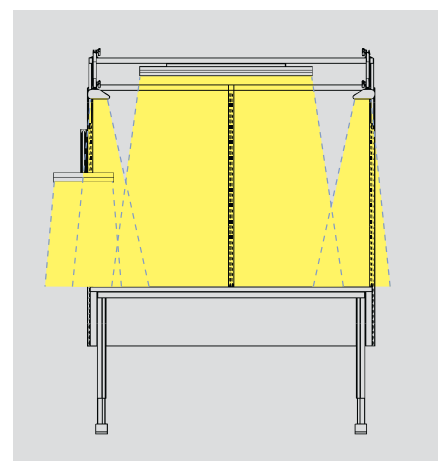



Lighting and balancer rails

Sovella industrial furnishings include ergonomic lighting solutions for every environment. Apart from spotlights all luminaries are fitted to light/balancer rails and to TowerLine shelf which are both height and depth adjustable.

Tool balancer rails and sliding pieces facilitate the use of heavy equipment. A tool balancer is fixed either to the light/balancer rail, or on a balancer arm fitted directly to the upright tube.



The pictures are not contractual. We reserve the right to modifications.

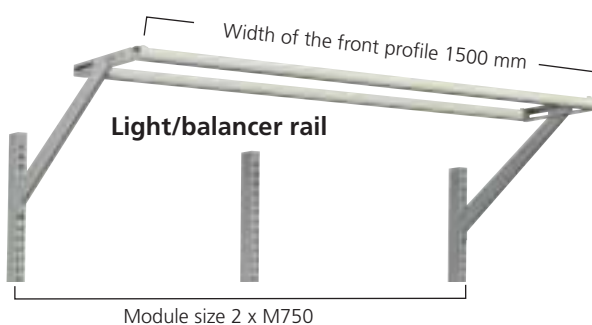

Lighting

name	order No
Side light 500, with an electronic starter	861 867-00
Light 1000, with an electronic starter	861 862-00
Task light	860 181-35

Light/balancer rail

module size	width of the front profile mm	max load kg	order No
2 x M500	1000	15	918 35 001
2 x M500/1500	1500	15	918 35 002
4 x M500	2000	15	918 35 003
M750	750	15	918 35 004
M750/1500	1500	15	918 35 005
2 x M750	1500	15	918 35 006
3 x M750	2250	15	918 35 012
M900	900	15	918 35 007
2 x M900	1800	15	918 35 008
M900/1500	1500	15	918 35 009
M1200	1200	15	918 35 010

Includes one sliding piece.

Tool balancers and other supplies

name	tool weight kg	order No
Tool balancer 2DU	0,5 - 1	939 502-00
Tool balancer 4DU	1 - 2	939 503-00
Balancer arm	8	846 678-35
Sliding piece		940 453-00

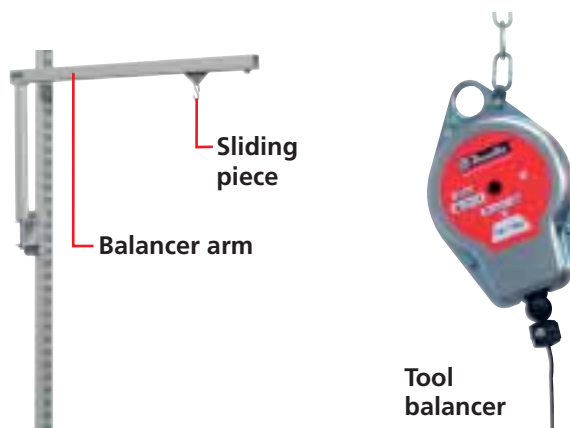
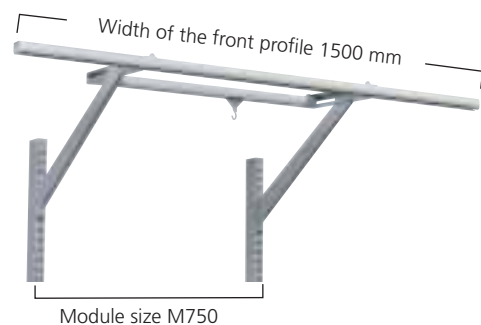



Energy rails, pneumatic rails, cable ducts and troughs

Energy rails are available in three module sizes: M500, M750 and M900. Cable ducts hide the untidy cables from other equipment. This makes it easy to keep the back of the workstation

and its surroundings tidy. Horizontal troughs effectively conceal the cables, without preventing maintenance access.

Energy rail

width mm	fixing	order No
1 440	8 sockets + on/off switch	vertical 910 51 001
2 440	6 sockets + fault current protection	vertical 910 51 002
M500	8 sockets + on/off switch	horizontal 911 51 001
4 M750	6 sockets + on/off switch	horizontal 911 51 002
M900	7 sockets + on/off switch	horizontal 911 51 003

Brackets included.

Pneumatic rails

connections, Ø 8 mm	in	out	fixing	order No
3 Pneumatic rail M750	1	3	horizontal	914 51 001
Pneumatic rail M900	1	3	horizontal	914 51 002

Connectors are compatible with the CEJN 3200 series.

Brackets included.

Cable ducts

name	size W x H mm	order No
Cable duct M500	467 x 360	860 808-35
Cable duct M750	717 x 360	860 044-35
Cable duct M900	870 x 360	860 045-35

Fitted to upright tubes.

Cable trough

name	size W x D x H mm	order No
Horizontal cable trough M750	737 x 97 x 45	854 553-35
Horizontal cable trough M900	890 x 97 x 45	854 554-35
Horizontal cable trough M1200	1187 x 97 x 45	854 555-35
Horizontal cable trough M1500	1487 x 97 x 45	854 556-35
Horizontal cable trough M1800	1793 x 97 x 45	854 557-35
Vertical cable trough	52 x 62 x 1360	861 130-35

1 Energy rail 440, 8 sockets



2 Energy rail 440, 6 sockets



3 Pneumatic rail M750

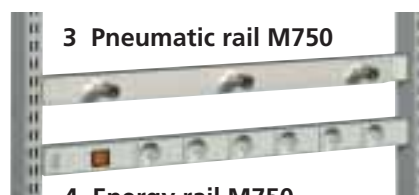

4 Energy rail M750 with 6 sockets



Hide wires and cables with a cable duct.



Fitted to upright tubes, the horizontal cable trough enables cables to be hidden at the top of the workstation.

The vertical cable trough is fitted on the side of the upright tube.



Shelves

Our extensive range of shelves includes various component sizes to complete your workstation. The deepest shelves should be installed at the top, thus not overloading the work surface. Adjustable shelves and extendable shelves enable

more ergonomic and efficient ways of working. The shelves are available in all module sizes. Steel shelves can be fitted at a 0° or 20° angle and adjustable shelves can be angled continuously from 0° to 25°.

Module sized steel shelf



Adjustable shelf



Steplessly adjustable shelf



Extendable shelf



Document shelf



Steel shelf M1500 with its extendable shelf



Shelves M500

name	module	size W x D mm	max load kg	order No
Steel shelf	M500	490 x 300	50	860 804-35
Steel shelf	M500	490 x 400	50	860 805-35
Adjustable shelf	M500	470 x 505	100	920 35 001
Adjustable shelf	M500	470 x 650	100	920 35 002
Adjustable shelf, stepless depth adjustment	M500	470 x 505	50	920 35 003
Adjustable shelf, stepless depth adjustment	M500	470 x 650	50	920 35 004
Document shelf (tilting 10-75°)	M500	470 x 265	5	860 806-35

Shelves M750

Steel shelf	M750	740 x 300	50	836 028-35
Steel shelf	M750	740 x 400	50	852 770-35
Adjustable shelf	M750	720 x 505	100	920 35 005
Adjustable shelf	M750	720 x 650	100	920 35 006
Adjustable shelf, stepless depth adjustment	M750	720 x 505	50	920 35 007
Adjustable shelf, stepless depth adjustment	M750	720 x 650	50	920 35 008
Extendable shelf	M750	720 x 390	30	925 35 002
Document shelf (tilting 10-75°)	M750	720 x 265	5	860 115-35

Shelves M900

Steel shelf	M900	890 x 300	50	852 283-35
Steel shelf	M900	890 x 400	50	852 769-35
Adjustable shelf	M900	870 x 505	100	920 35 009
Adjustable shelf	M900	870 x 650	100	920 35 010
Adjustable shelf, stepless depth adjustment	M900	870 x 505	50	920 35 011
Adjustable shelf, stepless depth adjustment	M900	870 x 650	50	920 35 012
Extendable shelf	M900	870 x 390	30	925 35 003
Document shelf (tilting 10-75°)	M900	870 x 265	5	860 399-35

Shelves M1200

Steel shelf	M1200	1167 x 300	80	854 480-35
Steel shelf	M1200	1167 x 400	80	854 483-35
Extendable shelf installed under shelf M1200 (depth 400 mm)	M1200	1120 x 355 x 50	30	925 35 005

Shelves M1500

Steel shelf	M1500	1467 x 300	80	854 481-35
Steel shelf	M1500	1467 x 400	80	854 484-35
Extendable shelf installed under shelf M1500 (depth 400 mm)	M1500	1420 x 355 x 50	30	925 35 006

Shelves M1800 + corner shelf

Steel shelf	M1800	1773 x 300	80	854 482-35
Steel shelf	M1800	1773 x 400	80	854 485-35
Extendable shelf installed under shelf M1800 (depth 400 mm)	M1800	1726 x 355 x 50	30	925 35 007
Corner shelf		1318 x 400	80	854 479-35

For the keyboard and mouse

Keyboard tray, fixed in front of shelf M1200/M1500/M1800	490 x 270	5	861 097-35
--	-----------	---	------------



Accessories

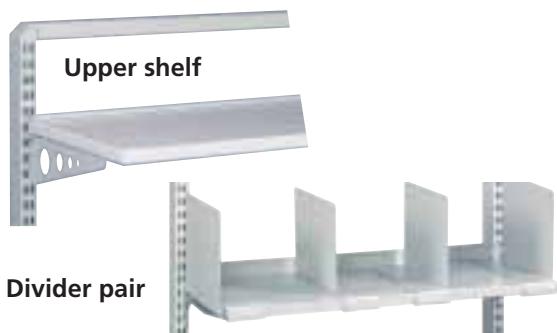

Upper shelf

Divider pair

Divider pair for shelves M500, M750 and M900

name	size D x H mm	order No
Divider pair	285 x 190	010 004-35
Divider pair	385 x 190	010 005-35

Divider pair for shelves M1200, M1500 and M1800

name	size D x H mm	order No
Divider pair	285 x 190	861 116-35

Auxiliary top left, ESD



Upper shelves, laminate

name	module	size W x D mm	max load kg	order No
Upper shelf	2 x M750*	1500 x 370	50	924 41 003
Upper shelf, ESD	2 x M750*	1500 x 370	50	924 35 003
Upper shelf	2 x M900*	1800 x 370	50	924 41 004
Upper shelf, ESD	2 x M900*	1800 x 370	50	924 35 004
Upper shelf	M1800**	1800 x 370	80	924 41 005
Upper shelf, ESD	M1800**	1800 x 370	80	924 35 005

* Upright tube needed in the middle, 2 x M750 = M1500, 2 x M900 = M1800

** Upright tube not needed in the middle, additional shelf support and back stop included. Used e.g. with the Basic packing table.

Back stop for upper shelf*

name	module size	order No
Back stop	M1500	852 549-35
Back stop	M1800	852 597-35

* Middle upright tube not needed in 50 kg upper shelves with back stop.

Auxiliary top, fixed brackets

name	size W x D mm	max load kg	order No
Auxiliary top left, ESD	400 x 500	40	926 35 001
Auxiliary top right, ESD	400 x 500	40	926 35 002
Auxiliary top left	400 x 500	40	926 41 001
Auxiliary top right	400 x 500	40	926 41 002

Sovella accessories provide ergonomics for improved productivity

Ergonomics is a wide concept

When a working environment is being set-up, the individual using it must come first. Employees cannot be fitted within a function or system that is only based on technical considerations. Therefore, the concept of ergonomics has to be broadened to encompass all human psychophysical activities. The main objectives of ergonomic design are ensuring employees' health, increasing work satisfaction and improving individual productivity.

A modular product family, a comprehensive selection of adjustable components and a wide range of accessories are our way of implementing ergonomics in the workplace. Our ultimate goal is to ensure a relaxed working position where the work movements can follow the individual's natural way of moving.

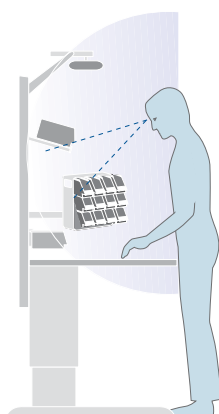
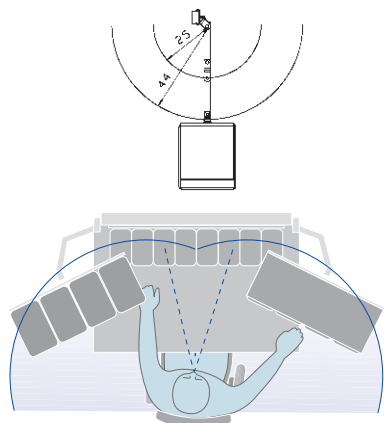

Don't reach for it!

First, the table top and shelves are adjusted to the correct height and the required accessories are installed. Then, tools and equipment are placed on adjustable, double-armed racks of various lengths. When everything is within the user's reach, valuable time is saved and the worktop is kept clean and hassle-free.



Accessories with arms

Adjustable auxiliary top

name	size W x D mm	tilting	max load kg	order No
Adjustable auxiliary top, ESD	560 x 340	0-25°	15	927 35 001
Adjustable auxiliary top, ESD	605 x 405	0-25°	15	927 35 002
Adjustable auxiliary top	560 x 340	0-25°	15	927 41 001
Adjustable auxiliary top	605 x 405	0-25°	15	927 41 002

Adjustable auxiliary top



IT shelves

name	size W x D mm	max load kg	order No
Monitor shelf with arm	365 x 365	25	930 35 001
Keyboard tray for monitor shelf	480 x 270	5	860 904-35
Keyboard and mouse tray for monitor shelf	620 x 270	5	860 903-35
LCD holder with double arm		15	930 35 002
Keyboard tray for LCD holder	480 x 260	5	860 941-35
Keyboard and mouse tray for LCD holder	620 x 260	5	860 942-35

Monitor shelf & keyboard tray



LCD-holder & keyboard tray



Document holders

name	size W x D mm	max load kg	order No
Document holder A4	290 x 330	5	928 35 008
Document holder A3	418 x 330	5	928 35 009

Document holder



Replacement arms (spare parts)

name	length mm	max load kg	order No
Double arm, 40 mm	200+200	10	880 020-35
Double arm, 60 mm	200+200	15	880 010-35
Heavy arm, 60 mm	287+221	30	860 993-35
Height-adjustable arm with gas spring, 60 mm	375	15	860 985-35
Height-adjustable profile (450 mm)		15	860 997-35
Light arm, table top fixing	200	5	860 990-35

Double arm

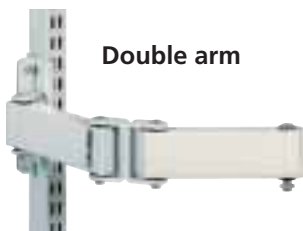

Heavy arm

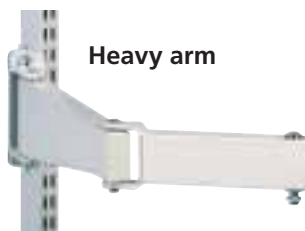

Light arm with table top fixing



When a position changes, the height must be adjusted

Frequent changes in the working position, such as changing from a sitting position to a standing position, require height-adjustable arm (860 985-35). The height-adjustable profile (860 997-35 in picture) can be attached to any rack with arm (such as the PC rack) that is pulled down and lifted back up according to the working position. The adjustment range is 450 mm.



Height-adjustable arm



Height-adjustable profile





Accessories

Apparatus stand



Box stand



Stand for plastic containers



Curved suspension rail with extension rail



Tool panel

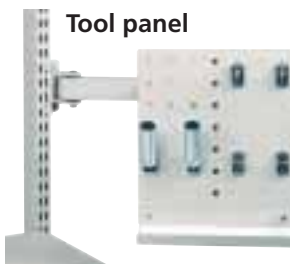

Rotating tool panel with perforated panel and R-hooks

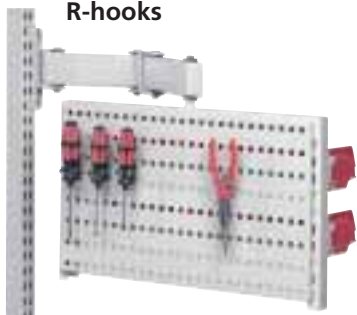

Racks

name	size W x D x H mm	max load kg	order No
Apparatus stand	250 x 250 x 90	10	928 35 001
Apparatus stand	500 x 250 x 125	15	928 35 002
Apparatus stand*	500 x 250 x 125	30	928 35 003
Box stand	560 x 175 x 125	15	928 35 005
Box stand	600 x 220 x 125	15	928 35 006
Stand for plastic containers**	560 x 165 x 355		931 35 000
Stand with 15 plastic containers 9080**	560 x 165 x 355		931 41 001
Stand with 15 plastic containers 9080, ESD**	560 x 165 x 355		931 35 001

*Comes with heavy arm.

**This stand can be placed on the box stand.

Suspension rails with arms

name	size W x H mm	max load kg	order No
Suspension rail with arm, straight	315 x 72	10	929 35 001
Curved suspension rail with arm	770 x 54	15	929 35 002
Extension for curved suspension rail with arm	770 x 54		860 911-35

Tool panel

name	size W x H mm	max load kg	order No
Tool panel	267 x 305	5	928 35 010

Rotating tool panels

name	module size	size W x H mm	max load kg	order No
Rotating tool panel, height-adjustable arm	M500	513 x 320	15	860 864-35
Rotating tool panel, double arm	M500	513 x 320	15	880 865-35
Perforated panel	M500	470 x 300		860 951-35
Tool trough	M500	470 x 150		860 952-35
Suspension rail	M500	492 x 90	50	860 811-35
Light suspension rail	M500	492 x 54	10	860 953-35

Rotating tool panel

The rotating tool panel can be equipped with perforated panels and tool troughs. The rotating tool panel is compatible with all M500 accessories, such as the tool trough and the suspension rails.

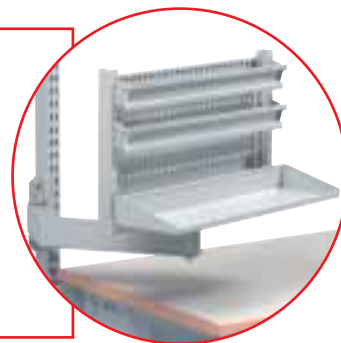

Rotating tool panel with M500 perforated panel, M500 suspension rails and 8 plastic ESD containers 9080



Plastic boxes, hooks and tools in pictures are not included.



Suspension rails

Another way of ensuring an ergonomic working position and saving space is to use suspension rails. The higher the stacks are, the further they are from the workstation. To ensure an ergonomic

working position, use deeper brackets on the top. The suspension rails are available in three standard module sizes: M500, M750 and M900.

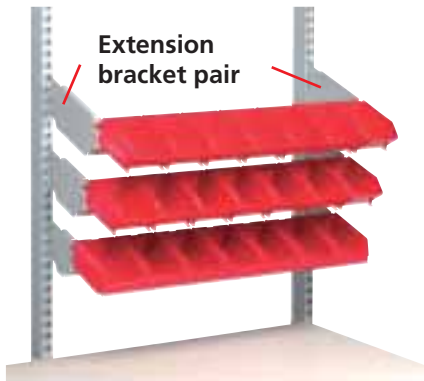

Suspension rail M750 with brackets and plastic containers.

Suspension rails

name	module	size W x H mm	max load kg	order No
Suspension rail	M500	492 x 90	50	860 811-35
Light suspension rail	M500	492 x 54	10	860 953-35
Suspension rail	M750	742 x 90	50	846 450-35
Light suspension rail	M750	742 x 54	10	860 955-35
Suspension rail	M900	895 x 90	50	852 025-35
Light suspension rail	M900	895 x 54	10	860 956-35
Extension bracket pair for a suspension rail		120		860 915-35
Extension bracket pair for a suspension rail		180		860 916-35
Extension bracket pair for a suspension rail		240		860 917-35



Suspension rail

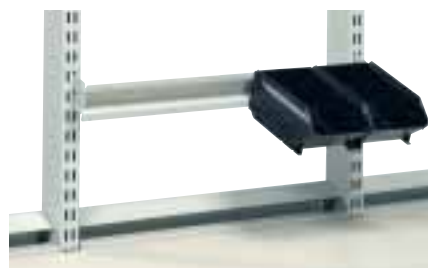

Light suspension rail

Plastic containers



Plastic containers

name	size W x D x H mm	capacity l	order No red	order No black (ESD)	order No plastic front+label	order No divider
9080	105 x 170 x 75	1	850 560-00	850 560-18		
9075	105 x 170 x 75	1	851 623-00	851 623-18	860 245-00	
9074	148 x 250 x 130	3,7	851 622-00	851 622-18	860 246-00	
9073	208 x 345 x 155	8,8	851 621-00	851 621-18	860 247-00	851 918-00

Fixing plastic containers on the curved suspension rail

Suspension rail	M500	M750	M900	curved suspension rail	suspension rail with arm, straight
9080	4	7	8	5	3
9075	4	7	8	5	3
9074	3	5	6		2
9073	2	3	4		



Accessories attached to the table top

Installing racks and rails on a table is sometimes the only solution. Our range also includes accessories with table top fixing.

The various accessories are shown with the arm version on page 38.

Armrest

The armrest ensures repetitive movements are executed ergonomically. The armrest can be adjusted for left- or right-handed users and is also height-adjustable. The ESD model includes a ground-connection cord.



Accessories attached on table top

name	size W x D x H mm	max load kg	order No
Apparatus stand with table top fixing	250 x 250 x 90	5	860 885-35
Document holder A4 with table top fixing	290 x 330	5	860 882-35
Tool panel with table top fixing	267 x 305	5	860 883-35
Suspension rail with table top fixing	315 x 72	5	860 884-35
Armrest			860 091-00
Armrest ESD			860 092-00
Extension tube for the armrest			860 093-51
Light arm, table top fixing	200	5	860 990-35



Document holder A4 with table top fixing

ESD accessories

When you want to build an efficient ESD workstation, we recommend grounding your employees, workstations and storage, via cables. Our basic grounding supplies include grounding cords and straps and junction boxes.

Grounding supplies

name	press button	resistance	order no
1 Fabric wrist strap, dark blue	7 mm		860 513-00
2 Spiral cord, dark blue, 1,8 m	7/10 mm	1 Mohm	860 515-00
3 Wristband junction box, yellow	3 x 10 mm	1 Mohm	860 526-00
4 Grounding cord, black, 1,5 m	10 mm/M5 terminal	1 Mohm	860 520-00
5 Ground junction box, yellow			860 522-00

ESD accessories

name	size W x D mm	order No
ESD table mat	1000 x 500	860 252-00
ESD mat	565 x 340	860 254-00
Ergo mat, ESD	950 x 650	852 880-00



2 Spiral cord, dark blue



3 Wristband junction box, yellow

4 Grounding cord, black



1 Fabric wrist strap, dark blue

5 Ground junction box



Accessories under the table top

The bar can be used to fix a footrest, a small cabinet or a holder for a computer. The bar is also needed in order to use the tilting frame on the Concept table.

Bars

name	table frame width mm	depth adjustment mm	order No
Bar Concept	1000	-	860 084-35
Bar Concept	1200	-	860 085-35
Bar Concept	1500	150	860 088-35
Bar Concept	1800	150	860 089-35
Bar Concept	2000	150	860 090-35
Bar TowerLine	M1200	-	861 056-35
Bar TowerLine	M1500	-	861 057-35
Bar TowerLine	M1800	-	861 204-35

The bar is included with the hand crank and motor Concept tables.

Footrests

size W x D mm	height	tilting	order No
1 Footrest, floor	550 x 350	100	5-30 860 947-35
2 Footrest, floor	550 x 350	90-280	5-30 860 137-35
3 Footrest, bar	550 x 350	90-280	5-30 860 136-35
4 Footrest, floor, with gas action	550 x 350	90-260	5-30 860 224-35
5 Footrest, bar, with gas action	550 x 350	90-260	5-30 860 196-35

1 Footrest, floor



2 Footrest, floor



3 Footrest, bar



4 Footrest, floor, with gas action



5 Footrest, bar, with gas action



CPU holder for Basic upright tube frame and Concept table

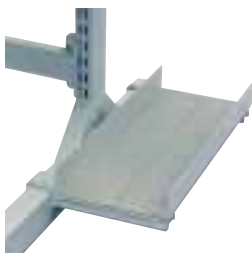

CPU holder, bar clamp



CPU holder for Basic table



CPU cabinet

CPU cabinets and holders

name	size W x D x H mm	max load kg	order No
CPU cabinet	325 x 550 x 560	40	861 120-35
CPU holder, bar clamp	>150 x 500 x 85	20	860 551-35
CPU holder, for Concept table	180-225 x 450 x 50	20	860 552-35
CPU holder, for Concept motor table	180-225 x 450 x 50	20	860 740-35
CPU holder, for Basic upright tube frame	180-225 x 450 x 50	20	860 553-35
CPU holder, for Basic table	180-225 x 450 x 50	20	854 440-35
Tool cabinet, fixed under table top	325 x 525 x 560	40	861 121-35

Fastening sets for CPU and tool cabinet see page 48.



Tool cabinet

Keyboard tray

name	size W x D mm	max load kg	order No
Keyboard tray, fitted under Basic or Concept table tops	630 x 400	10	925 35 001

Keyboard tray





Cone racks

The cone rack with base is used as a stand alone solution. The distance between the brackets is adjustable. The cone rack with hooks can be

attached to M750 upright tubes. It can also be used in our industrial cabinets.

Cone racks HSK, Capto, ISO

name	size W x D x H mm	order No
Cone rack with base	562 x 145 x 105	854 435-35
Foot extension for cone rack with base		854 420-35
Cone rack with hooks	742 x 188 x 90	854 430-35

Tool brackets	rack with base can hold pcs	rack with hooks can hold pcs	order No
ISO 50	6	8	837 770-00
HSK 40A/50B	7	9	854 215-00
HSK 63A/80B	5	7	854 217-00
HSK 100A/125B	5	7	854 219-00
Capto C4	7	9	854 201-00
Capto C5	7	9	854 202-00
Capto C6	4	6	854 203-00

Inserts for ISO 50 bracket	Ø mm	order No
ISO 45 Insert	45	837 730-00
ISO 40 Insert	40	837 710-00
ISO 30 Insert	30	837 690-00
Cylinder insert	50	852 311-00
Cylinder insert	40	852 310-00
Cylinder insert	30	852 309-00

Bit holders M750

name	hole Ø mm	holes pcs	order No
Bit holder 1	12,5	39	852 318-51
Bit holder 2	17	29	852 319-51
Bit holder 3	24	21	852 320-51
Bit holder 4	30	12	852 321-51



Cone rack with hooks



Cone rack with base



Bit holder

Small storage solutions



Perforated tool cabinet



Sliding door cabinet



File cabinet with two shelves

Small storage cabinets

name	module size	size W x D x H mm	max load kg	order No
Perforated tool cabinet, blue	M500	470 x 250 x 600	20	854 039-07
Perforated tool cabinet	M750	720 x 255 x 900	60	852 629-07
Shelf for M750 perforated tool cabinet		715 x 175 x 15	10	836 273-07/35
Sliding door cabinet	M750	720 x 370 x 400	40	860 970-35
Divider for sliding door cabinet		250 x 200		860 973-35
File cabinet with two shelves	M750	720 x 330 x 900	60	860 980-35
Divider pair for file cabinet		285 x 190		860 999-35
CD/folder box, fitted to upright tube		130 x 290 x 330	5	860 983-35



CD/folder box



Containers and pick up boxes

Plastic pick up boxes and containers help keep small parts organised. ESD versions are also available. Pick up boxes are often used with drawer unit interiors and containers for free stocking on cabinets and industrial shelves.



Container 9133 9068 9073 4530

Containers and pick up boxes

name	colour	size W x D x H mm	capacity l	order No	order No middle plate
Container 4530	blue	188 x 400 x 82	4,3	851 744-00	851 751-00
Container 9068	blue	230 x 400 x 150	11	851 747-00	852 565-00
Container 9073	red	208 x 345 x 155	8,8	851 621-00	851 918-00
Container 9133	red	230 x 600 x 100	12	852 500-00	852 558-00



Pick up box with divider

name	size W x D x H mm	capacity l	order No red	order No black/ESD
Pick up box with divider	149 x 85 x 48	0,5	851 843-00	851 846-18



Euro containers

name	colour	size W x D x H mm	capacity l	order No
Euro container 6487 ESD	black	300 x 200 x 145	6	806 094-18
Euro container 6468 ESD	black	400 x 300 x 145	13	806 095-18
Euro container 6469 ESD	black	400 x 300 x 230	20	806 096-18
Euro container 6472 ESD	black	600 x 400 x 145	25	806 097-18
Euro container 6479 ESD	black	600 x 400 x 230	44	806 098-18

Other supplies



Bottle holder



Bag holder

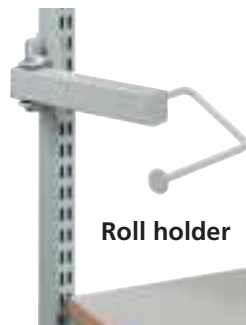

Roll holder

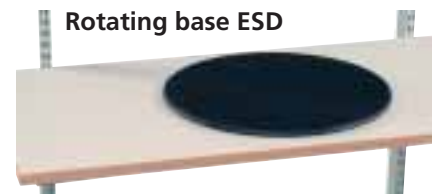

Rotating base ESD

Other supplies

name	Ø of the base mm	max load kg	order No
Bottle holder (Ø 80) for upright tube			860 842-35
Bag holder for table top lower edge			860 840-35
Roll holder for upright tube (roll Ø height 150 mm, width 175 mm)			860 841-35
Rotating base ESD	380	100	847 143-00
Rotating base ESD	500	100	847 144-00



Selecting a chair is a choice of ergonomics

The chair is a very important part of the ergonomics of a workstation. Even if the workstation is designed according to all rules of ergonomics,

a bad chair can destroy the final result. An ergonomic chair and a well-designed workstation make working pleasant and comfortable.



The chair must meet many demands

The ergonomics requirements we have set for our chairs can be summed up in three sentences: The chair must match the user. It must provide support in various working positions. It must be easy to adjust. In practice, this leads to a variety of adjustment possibilities. The height and rake adjustments of the backrest give support to the lower back area, and depth adjustment affects sitting comfort.

Different working positions are easy to select by tilting the seat. These are not the only adjustment possibilities. This is a good thing, because we are of very different sizes and each of us needs a suitable and comfortable chair.

Standing work is also possible

Our saddle chair offers change in working position. A saddle chair restricts strain on the pelvis and loads the back more evenly. The suitability of this chair for each task must be considered carefully.

In addition to chairs, our product range covers working stools and sit/stand stools. A sit/stand stool is good for work done both sitting and standing.



A correct chair for the correct environment

A chair cannot be taken from one environment to another. Those who work in EPA areas must use ESD-protected chairs, which are available with upholstery or polyurethane seats. The saddle chair is also available as ESD-protected. Most of the chairs have fabric upholstery,

but we also supply seats in beech and leather. Chairs used in certain environments must be durable and easy to clean. In these cases, a polyurethane chair is a good choice.



Armrests and foot ring must always be ordered separately.

Chairs with upholstery

name	description	sitting height	order No
1 Chair ESD	dark blue, glides	395 - 525	861 815-00
Chair ESD	dark blue, glides	485 - 675	861 816-00
Chair ESD	dark blue, wheels	420 - 550	861 817-00
Chair ESD	dark blue, wheels	510 - 700	861 818-00
2 Saddle chair ESD	dark blue, wheels	560 - 750	861 820-00
Saddle chair ESD	dark blue, wheels	740 - 970	861 821-00
Saddle chair	leather, wheels	560 - 750	861 822-00
Saddle chair	leather, wheels	740 - 970	861 823-00
3 Chair ESD*	dark blue	480 - 610	861 800-00
Chair ESD*	dark blue	570 - 760	861 801-00
4 Chair**	blue, glides	405 - 535	861 805-00
Chair**	blue, glides	495 - 685	861 806-00
Chair**	blue, wheels	430 - 560	861 807-00
Chair**	blue, wheels	520 - 710	861 808-00

Polyurethane chairs and stools

name	description	sitting height	order No
5 Chair*	black	365 - 490	852 452-00
Chair*	black	450 - 640	852 454-00
6 Chair ESD*	black	395 - 525	852 478-00
Chair ESD*	black	485 - 675	852 479-00
7 Stool*	black	340 - 465	860 194-00
Stool*	black	415 - 605	860 195-00
8 Sit/stand stool*	black	640 - 870	861 824-00

Wooden chairs and stools

name	description	sitting height	order No
9 Chair**	beech*	345 - 475	861 809-00
Chair**	beech*	435 - 625	861 810-00
10 Stool*	beech	345 - 465	861 812-00
Stool*	beech	435 - 615	861 813-00

Accessories for chairs

name	description	order No
Wheel set		861 830-00
Wheel set	ESD	861 829-00
Wheel set	friction, brakes without load	861 828-00
Wheel set	ESD, friction, brakes with load	861 827-00
Wheel set	ESD, friction, brakes without load	861 826-00
Glides	ESD, 35 mm	861 842-00
Glides	ESD, 60 mm	861 831-00
Foot ring		831 190-50
Armrests	ESD for chair no 5	860 538-00
Armrests	ESD, for chairs 1,3,4,6,9	861 838-00
Fastening set	for armrests of chairs 4 and 9	861 834-00

* For this model, wheels or glides must be ordered separately.

** Armrests require fastening set 861 834-00.





Drawer units

Versatile drawer units

Always where you need them

Since work is not always performed in the same place, we provide a comprehensive range of different drawer units for a variety of purposes.

You can fix any drawer units from the same series under a worktop or on a base unit, or equip them with wheels to take along to your next workstation.



Efficient storage and control

Our drawer units are great for storing tools and supplies. It can be surprising how much time is spent finding tools and other items if they are not stored systematically. The versatile interior combinations of our drawer units guarantee that your supplies are always at hand and in good order.





A comprehensive range of drawer units

We promise that you will find a drawer unit that meets your requirements in our comprehensive range. Our drawer units can be roughly divided into two categories: they are designed either for light or heavy loads.

You can choose from several different heights and drawer and interior combinations. We have selected some combinations for this brochure. Please ask about other available options: sales@sovella.com.

Drawer units for light loads

These drawer units are designed for storing lightweight items, for example in a testing laboratory or in an office environment.

Drawer unit 26



Drawer unit 35



Drawer unit 38



Drawer unit 45



Drawer unit 75



Drawer units for heavy loads

These robust drawer units are ideal for storing heavyweight supplies and tools, for example in a repair workshop or in the engineering industry.

Drawer unit 55



Drawer unit 71



Drawer unit 70



Drawer unit 90



Drawer unit 130



How to read the codes of drawer units

- The number included in the general name of the drawer unit refers to the base unit width in centimetres.
- The second number refers to the base unit height.
- The third number refers to the combination.

Example: **Drawer unit 45/56-1**

The drawer unit is 45 cm wide, 56 cm high and its combination number is 1.





Drawer units

Drawer units 26 and 35

These drawer units are fastened under a worktable to provide storage space and include either one or two drawers. The drawer cabinet comes with one drawer and a shelf with door. The cabinet can be equipped with wheels. The doors and drawers can be locked to protect the contents. More information about locks can be found on page 7.

Drawer units 26 and 35

name	size W x D x H mm	max load kg	order No
Drawer unit 26/15	265 x 450 x 148	10	860 395-35
Drawer unit 35/15	350 x 450 x 148	10	860 400-35
Drawer unit 26/22	265 x 450 x 220	20	860 060-35
Drawer unit 35/22	350 x 450 x 220	20	860 054-35
Drawer cabinet 35/47	350 x 450 x 470	25	860 972-35
Drawer cabinet 35/47 with wheels	350 x 450 x 555	25	860 918-35

Internal drawer dimensions: 215/300 x 400 x 70/120 mm.

Fastening sets

The fastening set should be selected according to the frame type and depth.

depth	600 mm	750 mm	900 mm
Concept worktable	860 931-35	860 930-35	860 239-35
Concept worktable with crank	-	860 930-35	-
Basic worktable	855 051-35	855 052-35	855 053-35

Fastening set for the TowerLine worktable and Concept motor table (all drawer units) 854 463-35. Not adapted to Concept handcrank table (depth 600 mm).



Drawer cabinet 35/47 is dimensioned so that upright folders fit inside.

Drawer units 38

Drawer unit 38 is attached under the worktable. It is available in two versions: with a fully extendable drawer and a 75% extendable standard-series drawer. Because of its size, drawer unit 38 is suitable for the same uses as drawer unit 26, while offering additional space and load capacity.

Drawer units 38

name	size	max load		order No
	W x D x H mm	kg/drawer	opening %	
Drawer unit 38/26-1	380 x 520 x 260	60	100	605 35 001
Drawer unit L-38/26-1	380 x 520 x 260	30	75	605 35 002

Internal drawer dimensions: 300 x 500 x 90 mm.

Fastening sets

The fastening set should be selected according to the frame type and depth.

depth	600 mm	750 mm	900 mm
Concept worktable	860 931-35	860 930-35	860 239-35
Concept worktable with crank	-	860 930-35	-
Basic worktable	855 051-35	855 052-35	855 053-35

Fastening set for the TowerLine worktable and Concept motor table (all drawer units) 854 463-35. Not adapted to Concept handcrank table or Concept motor table (depth 600 mm).



Pencil box for drawers 38 and 45

Add a pencil box in the drawer to organise small items more efficiently.

Name	For Drawer unit 38	For Drawer unit 45
Pencil box	854 851-35	854 850-35

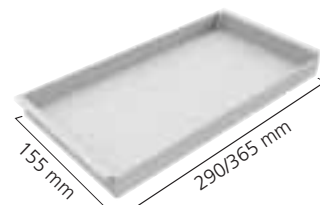



Drawer units 45

Choose from two frame heights: 56 or 66 cm, with base for a stand alone solution or with wheels for a trolley version. The drawer unit 45 can also be

attached to the table top. All the drawer units have central locking.

Choose the drawer unit according to your needs; with wheels, base or no base.



Connecting cables is easy with the removable back panel that can be opened from the inside.

Trolley model load capacity 150 kg, 4 swivel wheels (ø 100 mm), 2 with brakes. The trolley version comes with a rubber mat that stops items from sliding on the surface.

Drawer unit 45/56, 75% opening, load capacity 30 kg/drawer

	L-45/56-1	L-45/56-2	L-45/56-3	L-45/56-4	L-45/56-7
standard	606 35 001	606 35 002	606 35 003	606 35 004	606 35 007
with base	606 35 011	606 35 012	606 35 013	606 35 014	606 35 017
with wheels	606 35 021	606 35 022	606 35 023	606 35 024	606 35 027
height (mm) of the drawer	5 x 100	2 x 100	3 x 100	1 x 100	2 x 150
		2 x 150	1 x 200	2 x 200	1 x 200

Internal drawer dimensions:
370 x 500 x 90/140/190 mm.

Drawer unit 45/66, 75% opening, load capacity 30 kg/drawer

	L-45/66-1	L-45/66-2	L-45/66-3	L-45/66-4	L-45/66-5	L-45/66-6	L-45/66-7
standard	607 35 001	607 35 002	607 35 003	607 35 004	607 35 005	607 35 006	607 35 007
with base	607 35 011	607 35 012	607 35 013	607 35 014	607 35 015	607 35 016	607 35 017
with wheels	607 35 021	607 35 022	607 35 023	607 35 024	607 35 025	607 35 026	607 35 027
height (mm) of the drawer	6 x 100	3 x 100	1 x 100	4 x 150	4 x 100	2 x 100	3 x 200
		2 x 150	2 x 150		1 x 200	2 x 200	
			1 x 200				

Internal drawer dimensions:
370 x 500 x 90/140/190 mm.

Drawer unit 45/56, door right

	w/o lock	with lock
standard	606 35 105	606 35 108
with base	606 35 205	606 35 208
with wheels	606 35 305	606 35 308

Drawer unit 45/56, door left

	w/o lock	with lock
standard	606 35 106	606 35 109
with base	606 35 206	606 35 209
with wheels	606 35 306	606 35 309

Drawer unit 45/66, door right

	drawer 1 x 100	w/o lock	with lock
standard		607 35 108	607 35 110
with base		607 35 208	607 35 210
with wheels		607 35 308	607 35 310

Drawer unit 45/66, door left

	drawer 1 x 100	w/o lock	with lock
standard		607 35 109	607 35 111
with base		607 35 209	607 35 211
with wheels		607 35 309	607 35 311









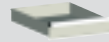

Cabinets include one bottom shelf and one adjustable shelf, shelf load capacity 50 kg.





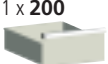











Drawer units

Drawer unit 45/56, 100% opening, load capacity 60 kg/drawer

	45/56-1	45/56-2	45/56-3	45/56-4	45/56-7	45/56-10	45/56-11
standard	606 35 101	606 35 102	606 35 103	606 35 104	606 35 107	606 35 110	606 35 111
with base	606 35 201	606 35 202	606 35 203	606 35 204	606 35 207	606 35 210	606 35 211
with wheels	606 35 301	606 35 302	606 35 303	606 35 304	606 35 307	606 35 310	606 35 311
height (mm) of the drawer	5 x 100 	2 x 100  2 x 150 	3 x 100  1 x 200 	1 x 100  2 x 200 	2 x 150  1 x 200 	2 x 100  1 x 300 	1 x 200  1 x 300 







Internal drawer dimensions:
370 x 500 x 90/140/190/290 mm.

Drawer unit 45/66, 100% opening, load capacity 60 kg/drawer

	45/66-1	45/66-2	45/66-3	45/66-4	45/66-5	45/66-6	45/66-7
standard	607 35 101	607 35 102	607 35 103	607 35 104	607 35 105	607 35 106	607 35 107
with base	607 35 201	607 35 202	607 35 203	607 35 204	607 35 205	607 35 206	607 35 207
with wheels	607 35 301	607 35 302	607 35 303	607 35 304	607 35 305	607 35 306	607 35 307
height (mm) of the drawer	6 x 100 	3 x 100  2 x 150 	1 x 100  2 x 150  1 x 200 	4 x 150 	4 x 100  1 x 200 	2 x 100  2 x 200 	3 x 200 

Internal drawer dimensions:
370 x 500 x 90/140/190 mm.

Drawer unit 45/66, 100% opening, load capacity 60 kg/drawer

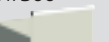
	45/66-12	45/66-13	45/66-14	45/66-15
standard	607 35 112	607 35 113	607 35 114	607 35 115
with base	607 35 212	607 35 213	607 35 214	607 35 215
with wheels	607 35 312	607 35 313	607 35 314	607 35 315
height (mm) of the drawer	3 x 100  1 x 300 	2 x 150  1 x 300 	1 x 100  1 x 200  1 x 300 	2 x 300 

Internal drawer dimensions:
370 x 500 x 90/140/190/290 mm.

Drawer 300 includes a folder support which makes organising hanging files easy.



The maximum load capacity of 100% extendable drawers is 60 kg!

Drawer units with wheels are also available as non ESD-versions (code 41 instead of 35).



A fully extendable drawer is perfect for laboratory use, for example.

Fastening sets

The fastening set should be selected according to the frame type and depth.

	600 mm	750 mm	900 mm
Concept worktable	860 931-35	860 930-35	860 239-35
Basic worktable	855 051-35	855 052-35	855 053-35

Fastening set for the TowerLine worktable and Concept motor table (all drawer units) 854 463-35. Not adapted to Concept handcrank table or Concept motor table (depth 600 mm).

Drawer interiors

Horizontal dividers

4x horizontal divider	
Drawer 45/100	872 980-35
Drawer 45/150 and 45/200	872 981-35



In the picture, the drawer unit 75/66 double door with a 100 mm drawer.



Drawer unit 75

Choose from two frame heights: 56 or 66 cm, with base for a stand alone solution or with wheels for

a trolley version. All the drawer units have central locking.



Trolley model: load capacity 150 kg, 4 swivel wheels (ø 100 mm), 2 with brakes. The trolley version comes with a rubber mat that stops items from sliding on the surface.



Choose the drawer unit according to your needs; with wheels, base or no base.



Cabinets include a bottom shelf and one adjustable shelf. Shelf load capacity 50 kg.

Drawer unit 75/56, 100 % opening, load capacity 60 kg/drawer

	75/56-1	75/56-2	75/56-3	75/56-4	75/56-7
standard	608 35 101	608 35 102	608 35 103	608 35 104	608 35 107
with base	608 35 201	608 35 202	608 35 203	608 35 204	608 35 207
with wheels	608 35 301	608 35 302	608 35 303	608 35 304	608 35 307
height (mm) of the drawer	5 x 100	2 x 100 2 x 150	3 x 100 1 x 200	1 x 100 2 x 200	2 x 150 1 x 200

Internal drawer dimensions: 670 x 500 x 90/140/190 mm.

The maximum load capacity of 100% extendable drawers is 60 kg!

Drawer unit 75/66, 100 % opening, load capacity 60 kg/drawer

	75/66-1	75/66-2	75/66-3	75/66-4	75/66-5	75/66-6	75/66-7
standard	609 35 101	609 35 102	609 35 103	609 35 104	609 35 105	609 35 106	609 35 107
with base	609 35 201	609 35 202	609 35 203	609 35 204	609 35 205	609 35 206	609 35 207
with wheels	609 35 301	609 35 302	609 35 303	609 35 304	609 35 305	609 35 306	609 35 307
height (mm) of the drawer	6 x 100	3 x 100 2 x 150	1 x 100 2 x 150 1 x 200	4 x 150	4 x 100 1 x 200	2 x 100 2 x 200	3 x 200

Internal drawer dimensions: 670 x 500 x 90/140/190 mm.

Drawer unit 75/56 double-door

	w/o lock	with lock
standard	608 35 105	608 35 106
with base	608 35 205	608 35 206
with wheels	608 35 305	608 35 306

Drawer unit 75/66 double-door

	drawer 1 x 100	w/o lock	with lock
standard		609 35 108	609 35 109
with base		609 35 208	609 35 209
with wheels		609 35 308	609 35 309

Drawer units with wheels are also available as non ESD-versions (code 41 instead of 35).

Fastening sets

The fastening set should be selected according to the table frame type and depth.

	600 mm	750 mm	900 mm
Concept worktable	860 931-35	860 930-35	860 239-35
Basic worktable	855 051-35	855 052-35	855 053-35

Fastening set for the TowerLine worktable and Concept motor table (all drawer units) 854 463-35. Not adapted to Concept handcrank table or Concept motor table (depth 600 mm).



Drawer interiors

Horizontal dividers

	4 x horizontal dividers
Drawer 75/100	872 985-35
Drawer 75/150	872 986-35
Drawer 75/200	872 986-35

Vertical dividers

	3 x vertical dividers
Drawer 75/100	872 988-35
Drawer 75/150	872 989-35
Drawer 75/200	872 989-35



Drawer units

Drawer unit 55

With these drawer units you can optimise your storage and keep all your items perfectly organised. The handy locking system allows only one drawer to be opened at a time. We recommend locking the drawers during transport. You can choose the best option from three heights to meet your needs, or add height or width with different drawer unit combinations.

worktable. The 66-cm-high drawer unit includes optional wheels, making it an excellent choice for a mobile workstation. The unit with wheels comes with a rubber mat that stops items from sliding on the surface. The version with doors is ideal for storing larger items. The 50 mm high drawer is fully extendable with a load capacity of 40 kg. The other drawers are 85% extendable with a load capacity of 80 kg.

The units also serve as worktable legs and the shallower drawers are easily fastened under a

Choose the drawer unit according to your needs; with wheels, base or no base.



Trolley model: load capacity 300 kg, 2 fixed wheels, 2 swivel wheels with brakes (ø 100 mm).

Drawer unit 55

model	55/13-1	55/37-1	55/37-2	55/37-3	55/37-4	55/37-5	55/37-6	55/37-7
order No	610 07 001	611 07 001	611 07 002	611 07 003	611 07 004	611 07 005	611 07 006	611 07 007
height (mm) of the drawer	1 x 100	1 x 50 1 x 100 1 x 150	3 x 100	2 x 150	3 x 50 1 x 150	1 x 50 1 x 250	2 x 50 2 x 100	6 x 50

Internal drawer dimensions: 460 x 612 x 35/85/135/235 mm.

Fastening sets

The fastening set should be selected according to the frame type and depth.

	750 mm	900 mm
Basic worktable	855 052-35	855 053-35
Fastening set not required for the Workshop table.		





Drawer unit 55/66

	55/66-1	55/66-2	55/66-3	55/66-4	55/66-5	55/66-8	55/66-9	55/66-10
standard	612 07 101	612 07 102	612 07 103	612 07 104	612 07 105	612 07 108	612 07 109	612 07 110
with base	612 07 201	612 07 202	612 07 203	612 07 204	612 07 205	612 07 208	612 07 209	612 07 210
with wheels	612 07 301	612 07 302	612 07 303	612 07 304	612 07 305	612 07 308	612 07 309	612 07 310
height (mm) of the drawer	3 x 50 	2 x 50 	1 x 50 	2 x 50 	1 x 50 	3 x 100 	2 x 100 	2 x 50
	3 x 100 	2 x 100 	4 x 100 	1 x 100 	3 x 100 	2 x 150 	1 x 150 	5 x 100
	1 x 150 	2 x 150 	1 x 150 	1 x 150 	1 x 250 		1 x 250 	
				1 x 250 				

	55/66-11	55/66-13	55/66-14	55/66-15	55/66-16	55/66-17	55/66-18	55/66-19
standard	612 07 111	612 07 113	612 07 114	612 07 115	612 07 116	612 07 117	612 07 118	612 07 119
with base	612 07 211	612 07 213	612 07 214	612 07 215	612 07 216	612 07 217	612 07 218	612 07 219
with wheels	612 07 311	612 07 313	612 07 314	612 07 315	612 07 316	612 07 317	612 07 318	612 07 319
height (mm) of the drawer	1 x 100 	4 x 50 	4 x 150 	6 x 100 	1 x 50 	12 x 50 	5 x 50 	6 x 50
	2 x 250 	1 x 100 			2 x 150 		1 x 100 	3 x 100
		2 x 150 			1 x 250 		1 x 250 	

	55/66-20	55/66-21
standard	612 07 120	612 07 121
with base	612 07 220	612 07 221
with wheels	612 07 320	612 07 321
height (mm) of the drawer	8 x 50 	2 x 50
	2 x 100 	2 x 250

Drawer unit 55/66-6 with door

	Door right	Door left
standard	612 07 106	612 07 107
with base	612 07 206	612 07 207
with wheels	612 07 306	612 07 307

Cabinets include bottom shelf.



Shelves for drawer unit 55/66 with door

name	size mm	max load kg	order No
E-shelf	455 x 612 x 61	80	854 106-35
Shelf	540 x 629 x 35	80	854 114-35

Drawer interiors



Tool troughs 33 and 45 mm

Drawer 55/50	834 122-00
--------------	------------

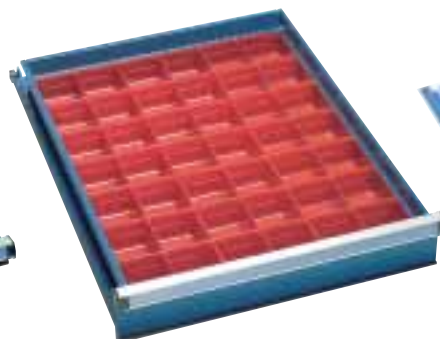

Pick up boxes

Drawer 55/100	851 866-00
---------------	------------

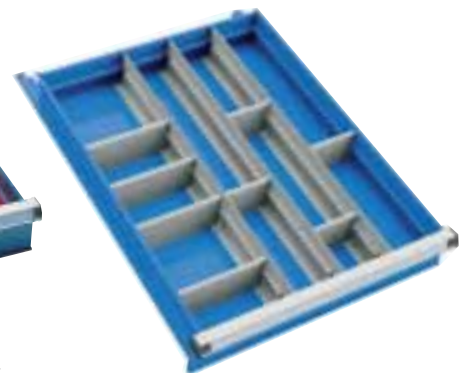

Middle dividers and plates 2

3 x middle divider, 6 x middle plate 150 and 6 x middle plate 100

Drawer 55/50	834 114-35
Drawer 55/100	834 203-35
Drawer 55/150	834 262-35
Drawer 55/250	834 262-35



Rubber mat for the drawer bottom

Rubber mat 55	852 717-00
---------------	------------



Drawer units

Drawer unit 55 combinations

It is possible to combine two drawer unit 55 frames with help of the TWIN set (combination 3). The

middle plate can be used to stack two drawer units 55 (combinations 1 and 2).

Combination 1

Order No C 612 07 901

includes	order No
55/66-4	612 07 304
55/37-1	611 07 001
Middle plate	854 103-35



Combination 2

Order No C 612 07 902

includes	order No
55/66-6	612 07 306
55/37-1	611 07 001
Middle plate	854 103-35
Shelf + brackets	854 114-35



Combination 3

Order No C 612 07 903

includes	size mm	order No
55/66-4		612 07 104
55/66-6		612 07 106
Twin set		854 108-41
Shelf + brackets		854 114-35
Table top	1200 x 750	860 554-66

Drawer unit 55 combinations

name	includes	order No
Combination 1	55/66-4 + 55/37-1	C 612 07 901
Combination 2	55/66-6 + 55/37-1	C 612 07 902
Combination 3	55/66-4 + 55/66-6	C 612 07 903

TWIN set

name	size mm	order No
Twin set		854 108-41
Table top	1200 x 750	860 554-66

The Twin set includes four swivel wheels Ø100 mm, two of which have brakes and plates to fix two frames together. The top is not included in the pack.

Middle plate

name	order No
Middle plate	854 103-35



Always remember to lock the drawer unit during transport!



Drawer unit 71

Less than 50 cm deep, this drawer unit is ideal for use in narrow spaces, such as in vehicles. The units come with a rubber mat that stops items from sliding on the surface. The drawers have ball bearings and safety locking so that only one drawer opens at a time.

This same drawer unit is used in the service trolley with wheels p. 73. The drawers are 90% extendable and their load capacity is 50 kg.



Drawer unit 71/79

model	71/79-1	71/79-2	71/79-3	71/79-4	71/79-5	71/79-6	71/79-7	71/79-8
order No	620 07 001	620 07 002	620 07 003	620 07 004	620 07 005	620 07 006	620 07 007	620 07 008
height (mm) of the drawer	3 x 75 	2 x 75 	1 x 75 	5 x 75 	2 x 75 	1 x 100 	1 x 100 	1 x 100
	1 x 125 	2 x 100 	4 x 100 	1 x 100 	2 x 100 	2 x 250 	2 x 125 	4 x 125
	1 x 250 	2 x 125 	1 x 125 	1 x 125 	1 x 250 		1 x 250 	

Internal drawer dimensions: 600 x 345 x 63/88/113/238 mm.

Drawer interiors

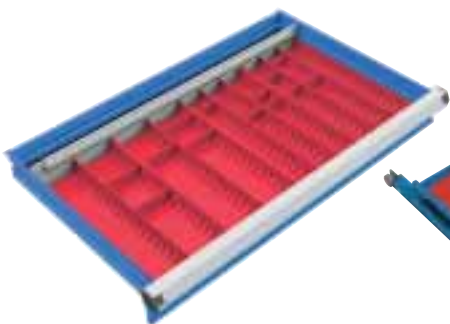

Tool troughs 33 and 45 mm

Drawer 71/75 854 066-00

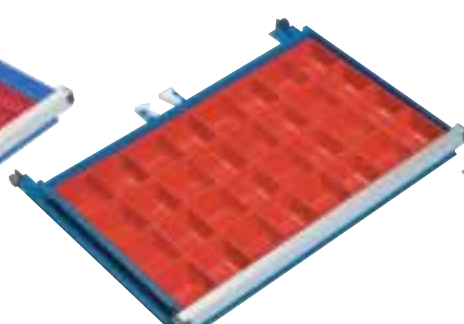

Pick up boxes

Drawer 71/75 854 064-00

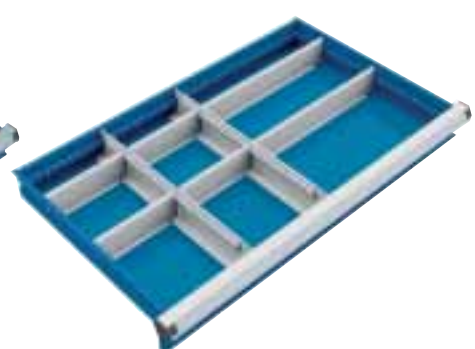

Middle dividers and plates 2

3 x middle divider, 6 x middle plate 150 and 2 x middle plate 300

Drawer 71/75 854 069-35

Drawer 71/100 854 070-35

Drawer 71/125 854 070-35

Rubber mat for the drawer bottom

Rubber mat 71 854 078-00





Drawer units

Drawer unit 70, 90 and 130

You can fit an amazing number of things in these spacious drawer units. Choose the one that best meets your needs from two heights: 110 and 140 cm. The 110-cm-high drawer units include a cover that doubles as a worktop with a rubber mat. This is the ideal height for working standing up.

The handy locking system allows only one drawer to be opened at a time. The drawer unit can be moved with a pallet truck or a forklift when the base front plate has been removed. The drawers are 85% extendable and their load capacity is 80 kg.

Drawing holder

name	W x H mm	order No
Drawing holder 70	706 x 500	834 939-35
Drawing holder 90	904 x 500	854 260-35
Drawing holder 130	1302 x 500	854 261-35

The optional drawing holder keeps your documents protected and easily available. The drawing table has a magnetic document fastening with 3 magnets included.



Drawer unit 70



The drawer units 70, 90 and 130 can be moved with a pallet truck or a forklift when the base front plate has been removed.

























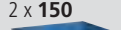











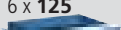









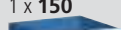

Drawer unit 70/110





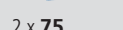



















model	70/110-1	70/110-2	70/110-3	70/110-4	70/110-5	70/110-6	70/110-7	70/110-8
order No	613 07 001	613 07 002	613 07 003	613 07 004	613 07 005	613 07 006	613 07 007	613 07 008
height (mm) of the drawer	2 x 100 3 x 150 1 x 250	2 x 75 3 x 100 3 x 150	9 x 100	2 x 75 2 x 100 2 x 150 1 x 250	2 x 50 1 x 100 3 x 150 1 x 250	2 x 50 4 x 100 1 x 150 1 x 250	3 x 50 4 x 75 2 x 100 1 x 250	2 x 50 2 x 75 1 x 100 2 x 150 1 x 250







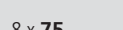



























Drawer unit 70/110

model	70/110-9	70/110-10	70/110-11	70/110-12	70/110-13	70/110-14	70/110-15	70/110-16
order No	613 07 009	613 07 010	613 07 011	613 07 012	613 07 013	613 07 014	613 07 015	613 07 016
height (mm) of the drawer	2 x 50  3 x 75  2 x 100  3 x 125 	2 x 50  3 x 75  1 x 125  1 x 150 	2 x 50  4 x 75  5 x 100 	2 x 75  6 x 100  1 x 150 	6 x 100  2 x 150 	2 x 50  5 x 100  2 x 150 	3 x 50  3 x 100  3 x 150 	1 x 50  1 x 100  6 x 125 

model	70/110-17	70/110-18	70/110-19	70/110-20	70/110-21	70/110-22	70/110-23	70/110-24
order No	613 07 017	613 07 018	613 07 019	613 07 020	613 07 021	613 07 022	613 07 023	613 07 024
height (mm) of the drawer	6 x 125  1 x 150 	3 x 75  4 x 100  1 x 125  1 x 150 	2 x 50  2 x 75  2 x 100  3 x 150 	8 x 75  3 x 100 	1 x 150  3 x 250 	2 x 50  4 x 75  2 x 250 	1 x 50  2 x 75  2 x 100  2 x 250 	12 x 50  4 x 75 

model	70/110-25	70/110-26	70/110-27	70/110-28	70/110-29	70/110-30	70/110-31	70/110-32
order No	613 07 025	613 07 026	613 07 027	613 07 028	613 07 029	613 07 030	613 07 031	613 07 032
height (mm) of the drawer	1 x 50  4 x 150  1 x 250 	1 x 50  2 x 100  1 x 150  2 x 250 	2 x 50  4 x 75  4 x 125 	15 x 50  2 x 75 	1 x 50  2 x 75  3 x 100  1 x 150  1 x 250 	3 x 50  2 x 75  2 x 100  1 x 150  1 x 250 	6 x 50  8 x 75 	12 x 75 

model	70/110-33	70/110-34	70/110-36	70/110-37	70/110-38	70/110-39	70/110-40	70/110-41
order No	613 07 033	613 07 034	613 07 036	613 07 037	613 07 038	613 07 039	613 07 040	613 07 041
height (mm) of the drawer	1 x 100  2 x 150  2 x 250 	6 x 150 	14 x 50  2 x 100 	1 x 50  2 x 75  7 x 100 	1 x 50  6 x 75  1 x 100  2 x 150 	2 x 50  2 x 150  2 x 250 	5 x 50  6 x 75  2 x 100 	8 x 50  4 x 75  2 x 100 

































model	70/110-42	70/110-43	70/110-44	70/110-45	70/110-46
order No	613 07 042	613 07 043	613 07 044	613 07 045	613 07 046
height (mm) of the drawer	2 x 75  5 x 100  2 x 125 	2 x 75  3 x 250 	3 x 100  4 x 150 	4 x 100  2 x 250 	8 x 75  2 x 150 

































Internal drawer dimensions: 612 x 612 x 35/60/85/110/130/235 mm.











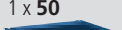
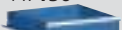







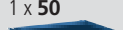

















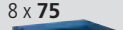





Drawer units













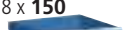
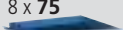

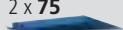

Drawer unit 70/140

model	70/140-1	70/140-2	70/140-3	70/140-4	70/140-5	70/140-6	70/140-7	70/140-8
order No	616 07 001	616 07 002	616 07 003	616 07 004	616 07 005	616 07 006	616 07 007	616 07 008
height (mm) of the drawer	2 x 75  5 x 100  2 x 150  1 x 250 	2 x 75  6 x 100  3 x 150 	4 x 100  2 x 150  2 x 250 	4 x 75  2 x 100  3 x 150  1 x 250 	2 x 50  3 x 100  2 x 150  2 x 250 	1 x 50  2 x 75  2 x 100  2 x 150  2 x 250 	1 x 50  4 x 75  3 x 100  2 x 150  1 x 250 	1 x 50  2 x 100  3 x 150  2 x 250 

model	70/140-9	70/140-10	70/140-11	70/140-12	70/140-13	70/140-14	70/140-15	70/140-16
order No	616 07 009	616 07 010	616 07 011	616 07 012	616 07 013	616 07 014	616 07 015	616 07 016
height (mm) of the drawer	4 x 50  2 x 75  3 x 100  2 x 150  1 x 250 	3 x 50  2 x 75  2 x 100  2 x 125  3 x 150 	2 x 50  4 x 75  4 x 100  1 x 150  1 x 250 	1 x 50  4 x 75  3 x 100  2 x 125  2 x 150 	6 x 75  1 x 100  2 x 125  1 x 150  1 x 250 	6 x 100  4 x 150 	12 x 50  8 x 75 	1 x 50  2 x 75  6 x 125  1 x 250 

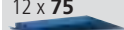
model	70/140-17	70/140-18	70/140-19	70/140-20	70/140-21	70/140-22	70/140-23	70/140-24
order No	616 07 017	616 07 018	616 07 019	616 07 020	616 07 021	616 07 022	616 07 023	616 07 024
height (mm) of the drawer	1 x 50  1 x 150  4 x 250 	1 x 50  12 x 75  1 x 100  1 x 150 	16 x 75 	3 x 100  6 x 150 	1 x 50  2 x 75  3 x 100  3 x 150  1 x 250 	24 x 50 	8 x 100  1 x 150  1 x 250 	12 x 100 

model	70/140-25	70/140-26	70/140-27	70/140-28	70/140-29	70/140-30	70/140-31
order No	616 07 025	616 07 026	616 07 027	616 07 028	616 07 029	616 07 030	616 07 031
height (mm) of the drawer	2 x 50  10 x 75  2 x 100  1 x 150 	10 x 75  3 x 100  1 x 150 	8 x 75  2 x 100  2 x 125  1 x 150 	6 x 75  3 x 100  3 x 150 	1 x 50  8 x 75  3 x 100  2 x 125 	4 x 50  6 x 75  4 x 100  1 x 150 	9 x 100  2 x 150 

model	70/140-33	70/140-34	70/140-35	70/140-36	70/140-37	70/140-38	70/140-39	70/140-40
order No	616 07 033	616 07 034	616 07 035	616 07 036	616 07 037	616 07 038	616 07 039	616 07 040
height (mm) of the drawer	1 x 50  6 x 150  1 x 250 	8 x 150 	8 x 75  6 x 100 	6 x 75  2 x 100  2 x 150  1 x 250 	2 x 75  2 x 150  3 x 250 	2 x 100  4 x 250 	12 x 75  2 x 150 	12 x 75  3 x 100 

Internal drawer dimensions: 612 x 612 x 35/60/85/110/130/235 mm.



Drawer interiors

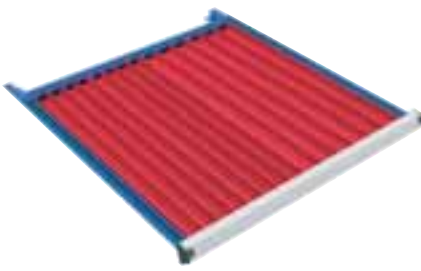

Tool troughs 33 and 45 mm

Drawer 70/50	837 911-00
Drawer 70/75	837 911-00



Tool troughs 45 and 70 mm

Drawer 70/50	837 938-00
Drawer 70/75	837 938-00

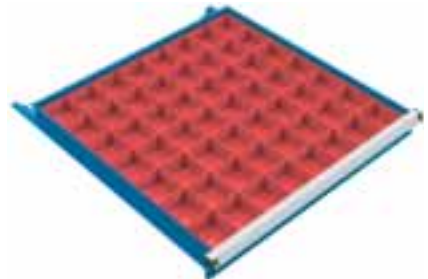

Pick up boxes

Drawer 70/75	851 867-00
--------------	------------

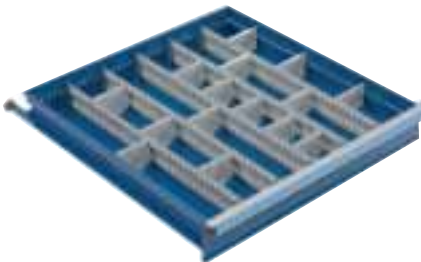

Middle dividers and middle plates 1

5x middle divider	
15x middle plate 100	
Drawer 70/50	837 946-35
Drawer 70/75	838 290-35
Drawer 70/100	837 970-35

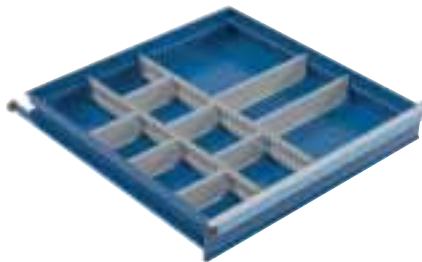

Middle dividers and middle plates 2

Set includes middle plates in 3 available widths. It allows you to create numerous interior solutions. One example shown in picture.	
3 x middle divider, 6 x middle plate 100, 6 x middle plate 150 and 2 x middle plate 300	
Drawer 70/50	837 954-35
Drawer 70/75	838 300-35
Drawer 70/100	837 989-35
Drawer 70/125	837 989-35
Drawer 70/150	838 004-35
Drawer 70/250	838 004-35



Rubber mat for the drawer bottom

Rubber mat 70	852 718-00
---------------	------------





Drawer units

Sliding door cabinet

Sliding doors are practical when there is little space in front of the drawer unit. When open, sliding doors make all of the contents visible. The sliding door cabinet is built to the same height as the drawer unit 70/110 to enable effective combinations. It is equipped with a transport base like the drawer unit 70 and the cover doubles as a worktop with a rubber mat. Drawers and E-shelves open 85 % and their loading capacity is 80 kg.



Sliding door cabinet

model	70/110-1	70/110-2	70/110-3	70/110-4	70/110-6	70/110-7	70/110-9	70/110-10
order No	619 07 001	619 07 002	619 07 003	619 07 004	619 07 006	619 07 0 07	619 07 009	619 07 010
height (mm) of the drawer	2 x 75 	1 x 100 	3 x E-shelf 	3 x 100 	1 x E-shelf 	3 x 75 	1 x 75 	5 x E-shelf
	2 x E-shelf 	2 x E-shelf 				2 x E-shelf 	7 x 100 	

model	70/110-11	70/110-13
order No	619 07 011	619 07 013
height (mm) of the drawer	2 x 50 	2 x 100
	2 x 250 	2 x E-shelf

Internal drawer dimensions:
612 x 612 x 35/60/85/235 mm.

Internal E-shelf dimensions: 612 x 612 mm.



Cone racks

The cone rack can be placed on an extendable shelf in the sliding door cabinet. The distance between each bracket is adjustable. The rack is equipped with handles.



Cone racks HSK, Capto, ISO

	size W x D x H mm	order No
Cone rack with base	562 x 145 x 105	854 435-35
Foot extension pair for cone rack with base		854 420-35

Tool brackets

	rack can hold pcs	order No
ISO 50	6	837 770-00
HSK 40A/50B	7	854 215-00
HSK 63A/80B	5	854 217-00
HSK 100A/125B	5	854 219-00
Capto C4	7	854 221-00
Capto C5	7	854 222-00
Capto C6	4	854 223-00

Inserts for ISO 50 bracket

	Ø mm	
ISO 45 Insert	45	837 730-00
ISO 40 Insert	40	837 710-00
ISO 30 Insert	30	837 690-00
Cylinder insert	50	852 311-00
Cylinder insert	40	852 310-00
Cylinder insert	30	852 309-00



Combinations with fully opening drawers and extendable shelves

In the drawer unit 70 and sliding door cabinet, the fully opening drawers and extendable shelves allow for the most efficient use of space. Each fully opening drawer and extendable shelf has a load capacity of up to

150 kg. They can also be integrated into heavy storage systems. Choose from ready-made combinations or contact your Sovella sales representative for a tailor-made combination.







Standard drawer

100 % opening drawer











Standard extendable shelf

100% opening extendable shelf

Drawer unit 70/110, drawers, 100% opening

model	70/110-51	70/110-69	70/110-72
order No	613 07 051	613 07 069	613 07 072
height (mm) of the drawer	6 x 100  2 x 150 	4 x 100  2 x 250 	9 x 100 

Drawer unit 70/140, drawers, 100% opening

model	70/140-32	70/140-45	70/140-51	70/140-54	70/140-58
order No	616 07 032	616 07 045	616 07 051	616 07 054	616 07 058
height (mm) of the drawer	8 x 100  1 x 150  1 x 250 	3 x 100  6 x 150 	2 x 100  4 x 250 	9 x 100  2 x 150 	12 x 100 

Sliding door cabinet 70/110, extendable shelves, 100% opening

model	70/110-8	70/110-14	
order No	619 07 008	619 07 014	
height (mm) of the drawer	3 x E-shelf 	4 x E-shelf 	



Drawer units

Drawer units 90

The drawers are 85% extendable and their load capacity is 80 kg.

Easy to move with pallet truck or fork lift.



Drawer unit 90/110

model	90/110-1	90/110-2	90/110-3	90/110-4	90/110-13	90/110-20	90/110-21	90/110-33
order No	614 07 001	614 07 002	614 07 003	614 07 004	614 07 013	614 07 020	614 07 021	614 07 033
height (mm) of the drawer	2 x 100 3 x 150 1 x 250 	2 x 75 3 x 100 3 x 150 	9 x 100 	2 x 75 2 x 100 2 x 150 1 x 250 	6 x 100 2 x 150 	8 x 75 3 x 100 	1 x 150 3 x 250 	1 x 100 2 x 150 2 x 250

model	90/110-34	90/110-35	90/110-43	90/110-44	90/110-45	90/110-46
order No	614 07 034	614 07 035	614 07 043	614 07 044	614 07 045	614 07 046
height (mm) of the drawer	6 x 150 	1 x 150 3 x 250 	2 x 75 3 x 250 	3 x 100 4 x 150 	4 x 100 2 x 250 	8 x 75 2 x 150







Drawer unit 90/140

model	90/140-1	90/140-2	90/140-3	90/140-4	90/140-14	90/140-19	90/140-23	90/140-24
order No	617 07 001	617 07 002	617 07 003	617 07 004	617 07 014	617 07 019	617 07 023	617 07 024
height (mm) of the drawer	2 x 75 5 x 100 2 x 150 1 x 250 	2 x 75 6 x 100 3 x 150 	4 x 100 2 x 150 2 x 250 	4 x 75 2 x 100 3 x 150 1 x 250 	6 x 100 4 x 150 	16 x 75 	8 x 100 1 x 150 1 x 250 	12 x 100

model	90/140-26	90/140-28	90/140-31	90/140-34	90/140-35	90/140-36	90/140-37	90/140-38
order No	617 07 026	617 07 028	617 07 031	617 07 034	617 07 035	617 07 036	617 07 037	617 07 038
height (mm) of the drawer	10 x 75 3 x 100 1 x 150 	6 x 75 3 x 100 3 x 150 	9 x 100 2 x 150 	8 x 150 	8 x 75 6 x 100 	6 x 75 2 x 100 2 x 150 1 x 250 	2 x 75 2 x 150 3 x 250 	2 x 100 4 x 250

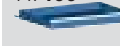

Drawer unit 90/140

model	90/140-39	90/140-40	90/140-42
order No	617 07 039	617 07 040	617 07 042
height (mm) of the drawer	12 x 75  2 x 150 	14 x 75  3 x 100 	1 x 100  4 x 150  2 x 250 

Internal drawer dimensions: 810 x 612 x 49/74/124/224 mm.

The large drawer units 90 and 130 include levelling screws, which help to level the unit on uneven surfaces.



Drawer interiors



Tool troughs 33 and 45 mm

Drawer 90/75 837 913-00

Tool troughs leave 50 mm free space on one side of the drawer.



Tool troughs 45 and 70 mm

Drawer 90/75 837 914-00

Tool troughs leave 50 mm free space on one side of the drawer.

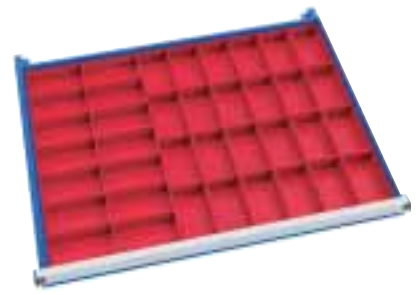

Pick up boxes

Drawer 90/75 851 870-00



Middle dividers and middle plates 2

The set includes middle plates in 3 available widths. It allows you to create numerous interior solutions. One example is shown in the picture.

3 x middle divider, 6 x middle plate 150 and 2 x middle plate 300

Drawer 90/75 851 950-35

Drawer 90/100 851 955-35

Drawer 90/150 851 958-35

Drawer 90/250 851 958-35



Horizontal dividers

4 x horizontal divider

Drawer 90/75 851 952-35

Drawer 90/100 851 957-35

Drawer 90/150 861 960-35

Drawer 90/250 861 960-35



Middle dividers and middle plates 4

7 x middle divider, 20 x middle plate 100

Drawer 90/75 854 880-35

Drawer 90/100 854 881-35

Drawer 90/150 854 882-35



Middle dividers and middle plates 5

5 x middle divider, 13 x middle plate 150

Drawer 90/75 854 883-35

Drawer 90/100 854 884-35

Drawer 90/150 854 885-35



Middle dividers and middle plates 6

5 x middle divider, 6 x middle plate 100 and 10 x middle plate 150

Drawer 90/75 854 886-35

Drawer 90/100 854 887-35

Drawer 90/150 854 888-35



Rubber mat for the drawer bottom

Rubber mat 90 854 080-00



Drawer units

Drawer units 130

Drawers open 85 % and their loading capacity is 80 kg.



Easy to move with pallet truck or fork lift.

Drawer unit 130/110

model	130/110-1	130/110-2	130/110-3	130/110-4	130/110-13	130/110-20	130/110-21	130/110-33
order No	615 07 001	615 07 002	615 07 003	615 07 004	615 07 013	615 07 020	615 07 021	615 07 033
height (mm) of the drawer	2 x 100 3 x 150 1 x 250 	2 x 75 3 x 100 3 x 150 	9 x 100 	2 x 75 2 x 100 2 x 150 1 x 250 	6 x 100 2 x 150 	8 x 75 3 x 100 	1 x 150 3 x 250 	1 x 100 2 x 150 2 x 250

















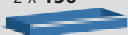

model	130/110-34	130/110-35	130/110-43	130/110-44	130/110-45	130/110-46
order No	615 07 034	615 07 035	615 07 043	615 07 044	615 07 045	615 07 046
height (mm) of the drawer	6 x 150 	1 x 150 3 x 250 	2 x 75 3 x 250 	3 x 100 4 x 150 	4 x 100 2 x 250 	8 x 75 2 x 150





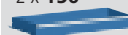

Drawer unit 130/140

model	130/140-1	130/140-2	130/140-3	130/140-4	130/140-14	130/140-19	130/140-23	130/140-24
order No	618 07 001	618 07 002	618 07 003	618 07 004	618 07 014	618 07 019	618 07 023	618 07 024
height (mm) of the drawer	2 x 75 5 x 100 2 x 150 1 x 250 	2 x 75 6 x 100 3 x 150 	4 x 100 2 x 150 2 x 250 	4 x 75 2 x 100 3 x 150 1 x 250 	6 x 100 4 x 150 	16 x 75 	8 x 100 1 x 150 1 x 250 	12 x 100



Drawer unit 130/140

model	90/140-26	90/140-28	90/140-31	90/140-34	90/140-35	90/140-36	90/140-37	90/140-38
order No	618 07 026	618 07 028	618 07 031	618 07 034	618 07 035	618 07 036	618 07 037	618 07 038
height (mm) of the drawer	10 x 75  3 x 100  1 x 150 	6 x 75  3 x 100  3 x 150 	9 x 100  2 x 150 	8 x 150 	8 x 75  6 x 100 	6 x 75  2 x 100  2 x 150  1 x 250 	2 x 75  2 x 150  3 x 250 	2 x 100  4 x 250 

model	90/140-39	90/140-40	90/140-42
order No	618 07 039	618 07 040	618 07 042
height (mm) of the drawer	12 x 75  2 x 150 	14 x 75  3 x 100 	1 x 100  4 x 150  2 x 250 

Internal drawer dimensions: 1208 x 612 x 49/74/124/224 mm.



Drawer interiors



Tool troughs 33 and 45 mm

Drawer 130/75 837 912-00

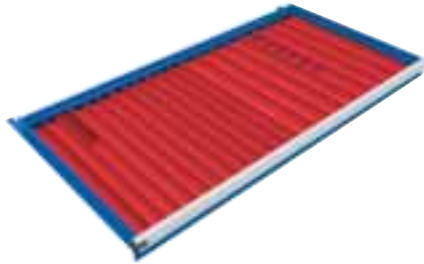

Tool troughs 45 and 70 mm

Drawer 130/75 837 939-00

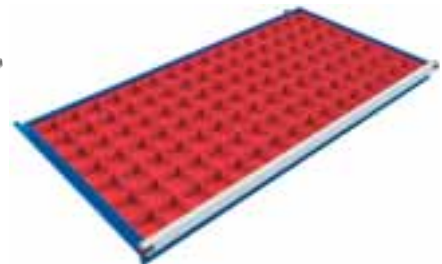

Pick up boxes

Drawer 130/75 851872-00



Middle dividers and middle plates 3

The set includes middle plates in 3 available widths. It allows you to create numerous interior solutions. One example is shown in the picture.

8 x middle divider, 15 x middle plate 100,
6 x middle plate 150 and 2 x middle plate 300

Drawer 130/75	851 881-35
Drawer 130/100	851 884-35
Drawer 130/150	851 887-35
Drawer 130/250	851 887-35

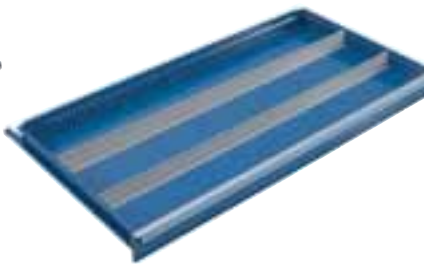

Horizontal dividers

4 x horizontal divider*

Drawer 130/75	851 882-35
Drawer 130/100	851 885-35
Drawer 130/150	851 888-35

*One interior example shown in the picture.



Middle dividers and middle plates 7

10 x middle dividers, 28 x middle plate 100*

Drawer 130/75	854 889-35
Drawer 130/100	854 890-35
Drawer 130/150	854 891-35

*One interior example shown in the picture.



Middle dividers and middle plates 8

6 x middle divider, 18 x middle plate 150

Drawer 130/75	854 892-35
Drawer 130/100	854 893-35
Drawer 130/150	854 894-35

*One interior example shown in the picture.



Rubber mat for the drawer bottom

Rubber mat 130 854 082-00



Trolleys

Freedom of mobility with trolleys

Sovella industrial trolleys cover both light and heavy industrial applications. Each trolley can be customised to suit the customer's requirements.



The wheels are equipped with brakes to ensure your safety on uneven surfaces.



Increased productivity with mobility

Work is not always confined to a single workstation and tools must be moved around accordingly. Lightweight trolleys are ideal for this situation, significantly increasing productivity up to 30%.

Each task is different and requires dedicated tools. Due to their modularity and versatile accessory components, trolleys are easy to design and adapt to suit a multitude of users and applications.





Light-duty trolleys provide solutions for storage as a buffer stock or additional ergonomic workspace.

150 kg



Worktop trolley

3 x 30 kg



Storage trolley

150 kg



Ergo trolley

300 kg



Multi trolley

350 kg



Basic trolley 3



Trolleys for heavy industry can support extremely heavy loads and yet can be easily transported. They are often used as repair stations with heavy tools.

300 kg



Fitter's trolley

600 kg



Heavy-duty trolley

300 kg



Basic trolley 4

300 kg



Service trolley





Trolleys

Light-duty trolleys for additional ergonomic workspace and storage

All the light-duty trolleys are equipped with four swivel wheels (ø 100 mm), two of which have brakes. ESD versions are also available.



Worktop trolley

A great solution when you need a mobile workspace. The height can be adjusted from 655 to 1055 mm.



Storage trolley

An easy solution for mobile storage, the storage trolley has an adjustable middle shelf, and the shelves are fitted with standard rubber mats.



Ergo trolley

The ergo trolley provides extra workspace. The height is continuously adjustable from 650 to 900 mm in the same way as the Concept work table. Lower shelf as an option.

Worktop and Storage trolleys

name	size W x D x H mm	max load kg	order No	order No ESD
Worktop trolley	750 x 600 x 655-1055	150	C 701 41 001	C 701 35 001
Storage trolley	650 x 450 x 775	3 x 30	852 773-41	852 773-35
Ergo trolley	750 x 500 x 650-900	150	860 422-41	860 422-35
Lower shelf for Ergo trolley	595 x 480			860 425-35

Multi trolleys

Multi trolleys provide an ergonomic mobile workstation. Multi trolleys are available in three different widths: M500, M750 and M900. This means that all our module-sized accessories can be

used with the trolleys. Multi trolleys are equipped with four swivel wheels (ø 100 mm), two of which have brakes. ESD versions are also available.

Multi trolleys

name	trolley width		
	M500	M750	M900
Multi trolley 1	C 721 35 001	C 721 35 002	C 721 35 003
Multi trolley 2	C 722 35 001	C 722 35 002	C 722 35 003



Multi trolley 1



Multi trolley 2

Adjustable shelf

Bottom shelf



Modular size

The modular (M) size refers to the distance between two upright tubes from the middle of the tube. The modular size is used to find the appropriate accessories.

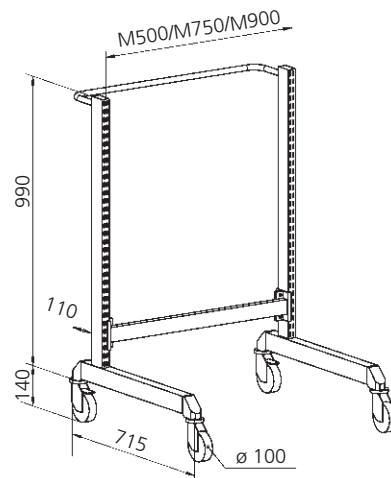
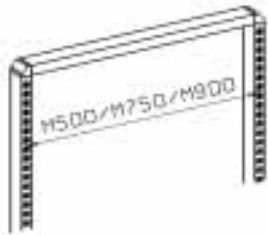

Multi trolley 1 frame

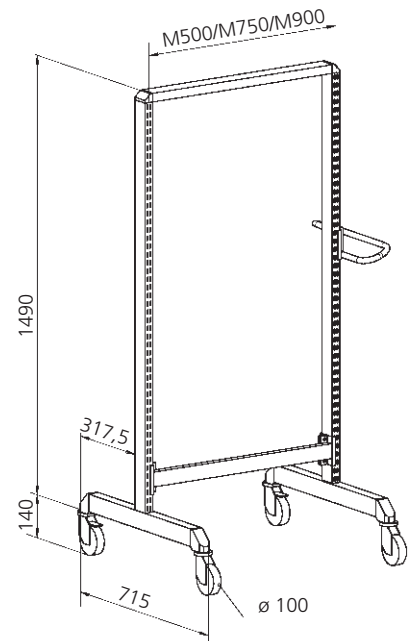

Multi trolley 2 frame

Multi trolley frame

name	module	size W x D x H mm	max load kg	order No	ESD order No
Multi trolley 1 frame	M500	530 x 715 x 1130	300	860 812-41	860 812-35
Multi trolley 2 frame	M500	530 x 715 x 1630	300	860 818-41	860 818-35
Multi trolley 1 frame	M750	780 x 715 x 1130	300	860 154-41	860 154-35
Multi trolley 2 frame	M750	780 x 715 x 1630	300	860 156-41	860 156-35
Multi trolley 1 frame	M900	935 x 715 x 1130	300	860 155-41	860 155-35
Multi trolley 2 frame	M900	935 x 715 x 1630	300	860 157-41	860 157-35

Bottom shelf

name	module	size W x D mm	max load kg	order No	ESD order No
Bottom shelf*	M500	470 x 505	100	860 846-41	860 846-35
Bottom shelf	M500	470 x 650	100	860 847-41	860 847-35
Bottom shelf*	M750	720 x 505	100	860 057-41	860 057-35
Bottom shelf	M750	720 x 650	100	860 067-41	860 067-35
Bottom shelf*	M900	870 x 505	100	860 059-41	860 059-35
Bottom shelf	M900	870 x 650	100	860 069-41	860 069-35

*Compatible only with Multi trolley 1.

Adjustable shelves are equipped with an ESD mat (35) or rubber mat (41).

Adjustable shelf

name	module	size W x D mm	max load kg	order No
Adjustable shelf	M500	470 x 505	100	921 35 001
Adjustable shelf	M500	470 x 650	100	921 35 002
Adjustable shelf	M750	720 x 505	100	921 35 005
Adjustable shelf	M750	720 x 650	100	921 35 006
Adjustable shelf	M900	870 x 505	100	921 35 009
Adjustable shelf	M900	870 x 650	100	921 35 010

Adjustable shelves are equipped with an ESD mat (35) or rubber mat (41).

Adjustable shelf, stepless depth adjustment

name	module	size W x D mm	max load kg	order No
Adjustable shelf, stepless depth adjustment	M500	470 x 505	50	921 35 003
Adjustable shelf, stepless depth adjustment	M500	470 x 650	50	921 35 004
Adjustable shelf, stepless depth adjustment	M750	720 x 505	50	921 35 007
Adjustable shelf, stepless depth adjustment	M750	720 x 650	50	921 35 008
Adjustable shelf, stepless depth adjustment	M900	870 x 505	50	921 35 011
Adjustable shelf, stepless depth adjustment	M900	870 x 650	50	921 35 012

Adjustable shelves are equipped with an ESD mat (35) or rubber mat (41).

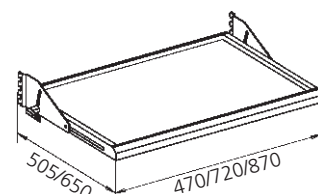
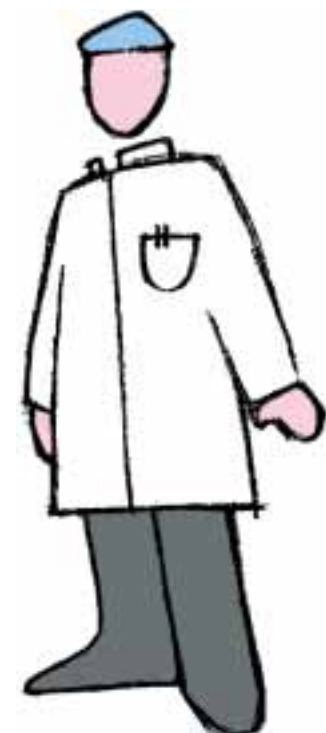



Trolleys

Heavy-duty trolleys

Heavy-duty trolleys, as their name indicates, are ideal for moving heavy loads. Their special wheels support extremely heavy weights. The total capacity of the basic model is up to

600 kg! The heavy-duty trolleys are equipped with two fixed wheels (ø 160 mm) and two swivel wheels with brakes.



Heavy-duty trolley 1

Order No C 750 41 001

Heavy-duty trolley 2

Order No C 750 41 002

Heavy-duty trolley 3

Order No C 750 07 003

Top 1000 x 750 mm

Worktop height 960 mm

Heavy-duty trolleys

name	size W x D x H mm	max load kg	order No
Heavy-duty trolley 1	935 x 785 x 940	600	C 750 41 001
Heavy-duty trolley 2	935 x 785 x 940	600	C 750 41 002
Heavy-duty trolley 3	1000 x 810 x 1640	600	C 750 07 003

Heavy-duty trolley 3

qty	name	size mm	order No
1	Bottom shelf	933 x 780	852 666-35
1	Perforated uprights,pair	661	852 668-35
1	Perforated uprights,pair	1359	852 667-35
1	Cross support, pair		852 669-35
1	Handle		852 670-35
1	Pvc-top, steel edges	1000 x 750	836 723-79
1	Corner hooks		848 336-35
1	Horizontal tube M900	873	840 104-35
2	Fixed wheel		900 040-00
2	Swivel wheels		900 041-00
1	Perforated panel	870 x 400	860 259-35
1	Suspension rail M900	895	852 025-35
6	Plastic box 9074		851 622-00
1	Fixing set		870 811-00
1	Drawer unit 55/37	550 x 715 x 370	611 07 001



For extremely heavy loads

The total capacity of the basic heavy-duty trolley is up to **600 kg**.



Heavy-duty trolley accessories

name	size W x D x H mm	max load kg	order No
Shelf	812 x 770 x 30	400	852 671-35
Cone bracket holder, ISO	812 x 770 x 52	500	852 673-35



The cone bracket holder can hold up to 48 ISO cone brackets.



Fitter's trolleys

A fitter's trolley with drawers lets you take your tools wherever you go, while keeping them organised. The rubber mat helps keep tools in place while you are working and the drawer unit comes equipped with a safety lock that allows only one drawer to be opened at a time. This helps to keep

the trolley in balance – even with heavy loads. The fitter's trolleys are equipped with four swivel wheels (ø 100 mm), two of which have brakes. Fitter's trolley can be combined with all M750 accessories.



Fitter's trolley 1



Fitter's trolley 2



Fitter's trolley 3

Fitter's trolley 3 includes 6 cone racks. Tool brackets, page 42, ordered separately.



Fitter's trolley 4

Modular size

The modular (M) size refers to the distance between two upright tubes from the middle of the tube. The modular size is used to find the appropriate accessories.

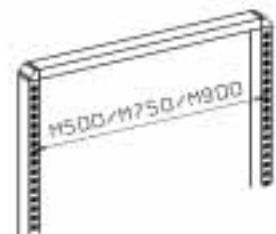

Fitter's trolleys

name	mod.	size W x D x H mm	max load kg	order No
Fitter's trolley 1	M750	800 x 715 x 855	300	C 730 41 001
Fitter's trolley 2	M750	800 x 715 x 855	300	C 730 41 002
Fitter's trolley 3	M750	800 x 715 x 855	300	C 730 41 003
Fitter's trolley, frame	M750	800 x 715 x 855	300	C 730 41 000
Fitter's trolley 4		795 x 715 x 915	300	C 730 07 004

Fitter's trolley accessories

name	size W x D x H mm	max load kg	order No
Bottom shelf with rubber mat	720 x 560 x 32	150	852 719-41
Bottom shelf with HDPE plastic covering	720 x 560 x 32	150	852 683-41
Shelf with rubber mat	720 x 560 x 32	150	852 720-41
Shelf with HDPE plastic covering	720 x 560 x 32	150	852 684-41
Extendable shelf + brackets	720 x 580 x 33	50	852 687-35

Fitter's trolleys can be combined with all M750 accessories.

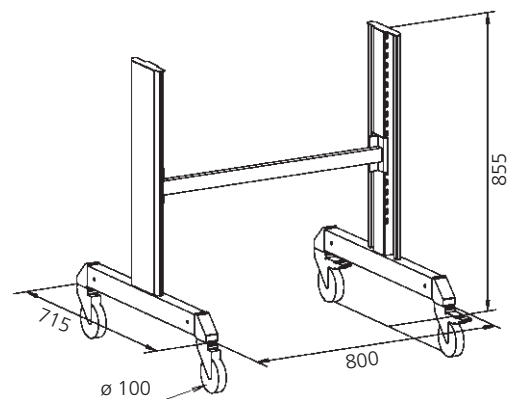



Trolleys

Basic trolleys

Equip your trolleys with shelves, tops and other accessories to fit any application, such as transportation or tool storage. All trolleys are

equipped with four swivel wheels (ø 150 mm), two of which have brakes. The basic trolley can be combined with all the M750 accessories.



Basic trolley 1



Basic trolley 2



Basic trolley 3



Basic trolley 4



Basic trolley 5

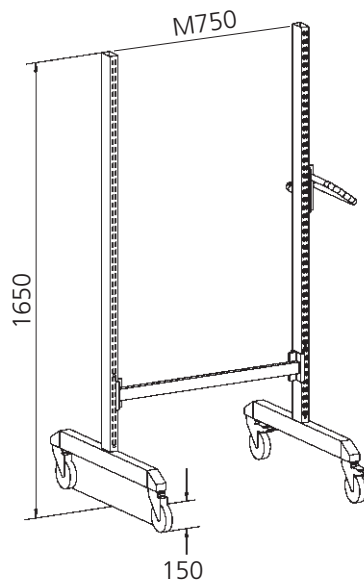

Basic trolley frame

Basic trolleys

name	size W x D x H mm	max load kg	order No
Basic trolley 1	800 x 715 x 1650	350	C 740 41 001
Basic trolley 2	800 x 715 x 1650	350	C 740 07 002
Basic trolley 3	800 x 715 x 1650	350	C 740 41 003
Basic trolley 4	800 x 715 x 1650	350	C 740 07 004
Basic trolley 5	800 x 715 x 1650	350	C 740 07 005
Basic trolley frame	800 x 715 x 1650	350	C 740 41 000

Basic trolley accessories

name	size W x D x H mm	max load kg	order No
Bottom shelf with rubber mat	720 x 560 x 32	150	852 719-41
Bottom shelf with HDPE plastic covering	720 x 560 x 32	150	852 683-41
Shelf with rubber mat	720 x 560 x 32	150	852 720-41
Shelf with HDPE plastic covering	720 x 560 x 32	150	852 684-41
Extendable shelf + brackets	720 x 580 x 33	50	852 687-35
Wash basket L-300	380 x 302 x 110	20	839 116-51
Waste basket			839 159-00
Waste basket holder			835 773-35
Paper roll holder (roll dimensions max: width 240 mm, ø 230 mm)			860 310-35

Trolleys can be combined with all the M750 accessories. For perforated panels, see p. 88, for R-hooks, see p. 90.



Service trolleys

The service trolley frame is equipped with a safety locking feature that allows only one drawer to be opened at a time. The cover comes as standard with a separate rubber mat that prevents items from slipping.

Both sides of the trolley have standard, perforated panels that you can accessorise with brackets and mountings, to suit any application. Service trolleys are also equipped with two fixed wheels (ø 150 mm) and two swivel wheels including brakes (ø 100 mm).

Customize your service trolley with a selection of hooks from p. 90-93.



Service trolley

Size 710 x 480 x 875 mm
Max load 300 kg

Service trolleys

model	Service trolley-1	Service trolley-2	Service trolley-3	Service trolley-4	Service trolley-5	Service trolley-6	Service trolley-7	Service trolley-8
order No	710 07 001	710 07 002	710 07 003	710 07 004	710 07 005	710 07 006	710 07 007	710 07 008
height (mm) of the drawer	3 x 75	2 x 75	1 x 75	5 x 75	2 x 75	1 x 100	1 x 100	1 x 100
	1 x 125	2 x 100	4 x 100	1 x 100	2 x 100	2 x 250	2 x 125	4 x 125
	1 x 250	2 x 125	1 x 125	1 x 125	1 x 250		1 x 250	

Internal drawer dimensions: 600 x 345 x 63/88/113/238 mm.

Accessorised service trolley

By attaching the upright tube pair 30 x 30 mm 854 038-35, you can use all the M500 accessories.

Accessories for service trolley

qty	name	size mm	order no
1	Perforated upright pair	30 x 30 x 1219	854 038-35
1	Perforated tool cabinet	200 x 600 x 470	854 039-07
1	Suspension rail	M500	860 953-35
5	Plastic container 9075		851 623-00
1	Vice support		854 037-06
1	Pick-up box holder	165 x 48 x 456	854 042-35
4	Pick-up box	149 x 85 x 48	851 843-00
1	Utility box	155 x 90 x 410	854 041-35
1	Paper roll dispenser		854 043-35
1	Waste bucket holder		854 044-35
1	Waste bucket		839 159-00
1	Folder compartment	466 x 90 x 240	854 040-35



Drawer interiors

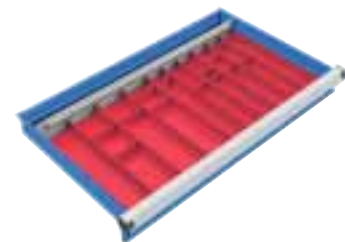

Tool troughs 45 and 70 mm

Drawer 71/75 854 066-00

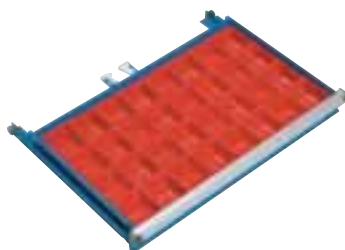

Pick up boxes

Drawer 71/75 854 064-00



Rubber mat for the drawer bottom

Rubber mat 71 854 078-00

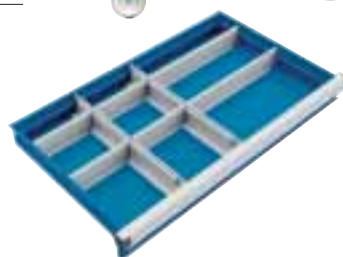

Middle dividers and plates 2

3 x middle divider, 6 x middle plate 150 and 2 x middle plate 300

Drawer 71/75 854 069-35

Drawer 71/100 854 070-35

Drawer 71/125 854 070-35



Industrial shelving and cabinets

There is a place for each item

Shelves and cabinets are needed to keep the workplace in good order. We have a large range of products, and the product families are presented in more detail on these pages. In selection of furniture

elements, the space dimensions and the load capacity needed should be considered. Shelves are also excellent as space dividers. ESD protection is also available.



Extended tool life

The service life and condition of tools can be significantly improved through their appropriate storage. They are stored in their own places, protected from dust and dirt, in a locked cabinet.

A versatile storage solution is created by using suitable accessories

An open shelf is not always the best way to store things. Tools, expensive equipment, and small items need another type of solution. Through using lockable drawers or adding doors and walls, an open shelving system is turned into a versatile storage solution. Drawers can be fitted with a variety of interior combinations, to suit the tools stored in them.

The Sovella Storage System is modifiable

A storage system is built around the basic component, and extension parts, doors, screens, and other accessories can be added to create an efficient overall solution. In addition the shelf heights can easily be adjusted as needed. Even the load capacity can be increased by adding additional supports.



The Sovella Heavy Storage System is designed for heavy items

When the items are heavy, shelves need to be very strong as well. Computer servers or large measurement instruments can be surprisingly heavy. A heavy storage system is designed for load capacities of up to 400 kg/shelf.

Sovella Industrial Cabinets allow for a tidy, efficient working environment

No unnecessary time should be used for looking for tools and materials. This interrupts work and causes stress. In a well-equipped cabinet, everything is where it should be. A ready-assembled cabinet is easy to move to the most convenient location. There are adjustable glides under the cabinet. This makes it easy to adjust the cabinet so that it stands straight on uneven surfaces. All module-750 and -500 accessories, such as shelves, drawer units, perforated panels, and extendable shelves, can be used in selecting accessories for the cabinet.





Industrial shelving and cabinets

Storage System

The Sovella storage system can be built as a combination of cabinets and shelves and you can use it as a space divider.

The storage system is available in two standard heights: 200 cm and 240 cm and two widths: 80 cm and 100 cm.



All standard and extension parts include 6 shelves.

Standard parts

name	size W x D x H mm	order No
Standard part 80/30/200	824 x 300 x 2000	C 313 35 001
Standard part 80/40/200	824 x 400 x 2000	C 314 35 001
Standard part 100/30/200	1024 x 300 x 2000	C 313 35 002
Standard part 100/40/200	1024 x 400 x 2000	C 314 35 003
Standard part 100/50/200	1024 x 500 x 2000	C 315 35 001
Standard part 100/60/200	1024 x 600 x 2000	C 316 35 001
Standard part 80/40/240	824 x 400 x 2400	C 314 35 002
Standard part 100/40/240	1024 x 400 x 2400	C 314 35 004
Standard part 100/50/240	1024 x 500 x 2400	C 315 35 002
Standard part 100/60/240	1024 x 600 x 2400	C 316 35 002

Extension parts

name	size W x D x H mm	order No
Extension part 80/30/200	804 x 300 x 2000	C 323 35 001
Extension part 80/40/200	804 x 400 x 2000	C 324 35 001
Extension part 100/30/200	1004 x 300 x 2000	C 323 35 002
Extension part 100/40/200	1004 x 400 x 2000	C 324 35 003
Extension part 100/50/200	1004 x 500 x 2000	C 325 35 001
Extension part 100/60/200	1004 x 600 x 2000	C 326 35 001
Extension part 80/40/240	804 x 400 x 2400	C 324 35 002
Extension part 100/40/240	1004 x 400 x 2400	C 324 35 004
Extension part 100/50/240	1004 x 500 x 2400	C 325 35 002
Extension part 100/60/240	1004 x 600 x 2400	C 326 35 002

All standard and extension parts include 6 shelves

The W x D x H rule

All our dimensions follow a WDH rule, where the first dimension is the width (W), the middle the depth (D), and the last the height (H).

Combination name

100/30/200-1

Width cm

Depth cm

Height cm

Version

Load capacity

1000 kg/part

width 824 mm



150 kg/shelf

width 1024 mm



150 kg/shelf



Storage System Combinations



100/30/200-8 C 340 07 008

qty	name	size mm	order No
3	End frame/open	300 x 2000	830 615-35
8	Shelf+brackets	1000 x 300	852 175-35
2	Perforated panel	949 x 988	837 334-07
2	Cross support pair 1000		852 176-35
2	Fixinf set		852 278-35



100/40/200-1 C 334 07 001

qty	name	size mm	order No
1	Storage cabinet	1024 x 400 x 2000	C 334 07 000
4	Shelf	1000 x 400	852 231-35

Move with a pallet truck

The cabinet can be moved with a pallet truck or a forklift when the plinth front panel has been removed. Cabinets are equipped with adjustment screws.



100/40/200-4 C 334 07 004

qty	name	size mm	order No
1	Storage cabinet	1024 x 400 x 2000	C 334 07 000
2	Shelf	1000 x 400	852 231-35
1	Perforated panel	949 x 988	837 334-07
3	Drawer 400		834 513-35
1	Fixing set		852 278-35



100/40/200-9 C 340 07 009

qty	name	size mm	order No
2	End frame/open	400 x 2000	830 895-35
14	Shelf+brackets	1000 x 400	852 231-35
2	Cross support pair 1000		852 176-35
1	Perforated panel	949 x 988	837 334-07
1	Storage cabinet	1024 x 400 x 2000	C 334 07 000
1	Fixing set		852 278-35



Industrial shelving and cabinets

The Sovella Storage System includes a wide range of different parts which can be used to create a fully tailor-made solution.

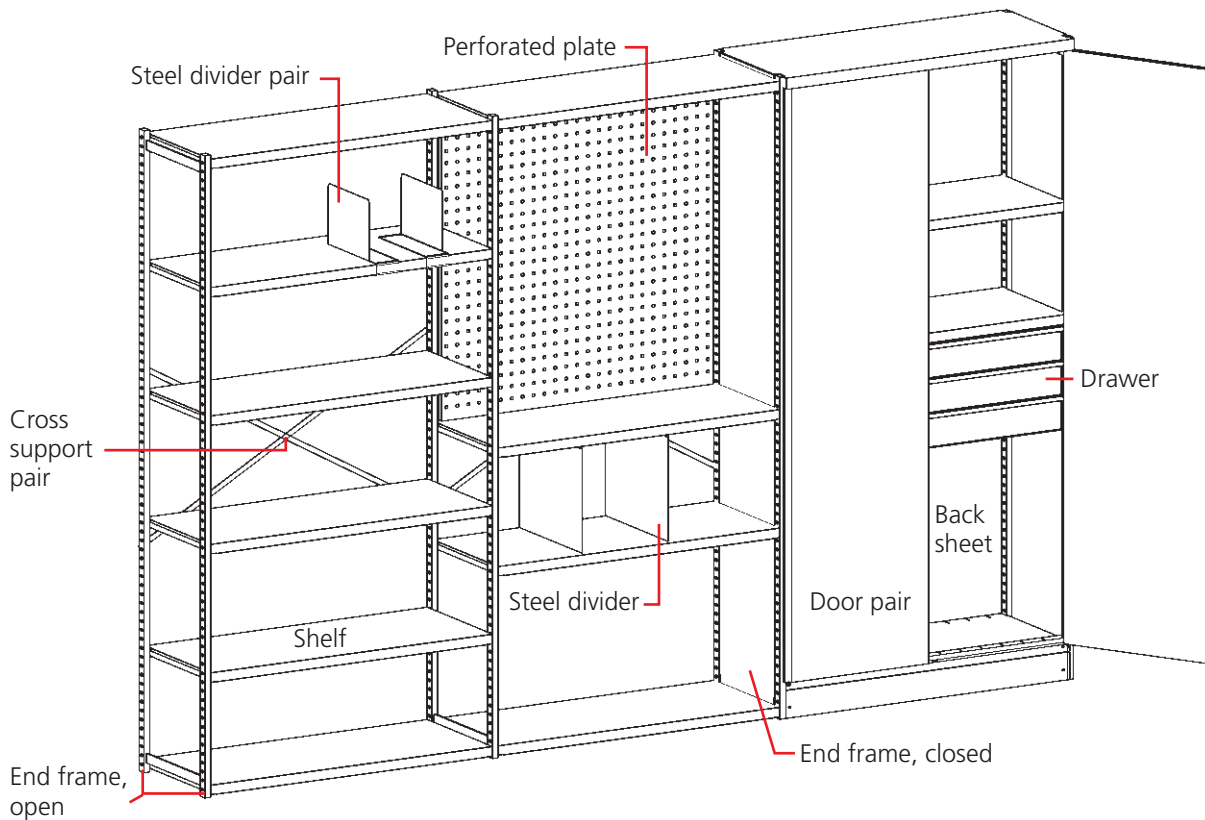

Storage system components

name	size D x H mm	order No
End frame, open	300 x 2000	830 615-35
End frame, open	400 x 2000	830 895-35
End frame, closed	400 x 2000	852 144-35
End frame, open	500 x 2000	851 719-35
End frame, closed	500 x 2000	852 243-35
End frame, open	600 x 2000	851 725-35
End frame, closed	600 x 2000	852 256-35
End frame, open	400 x 2400	851 717-35
End frame, open	500 x 2400	851 721-35
End frame, open	600 x 2400	851 724-35
Cross support pair 800		852 236-35
Cross support pair 1000		852 176-35
Cabinet 100/40/200	1024 x 400 x 2000	C 334 07 000
Cabinet 100/50/200	1024 x 500 x 2000	C 335 07 000
Cabinet 100/60/200	1024 x 600 x 2000	C 336 07 000
Cabinet, extension part 100/40/200	1004 x 400 x 2000	C 337 07 000
Cabinet, extension part 100/50/200	1004 x 500 x 2000	C 338 07 000
Cabinet, extension part 100/60/200	1004 x 600 x 2000	C 339 07 000
Back sheet 1000		832 863-35
Perforated end plate 400	340 x 2000	830 917-07
Screw set (fixing back to back)		838 440-51
Perforated panel 1000	949 x 988	837 334-07
Fixing set/perforated plate		852 278-35
Additional support for shelf 1000		852 267-35

Drawers and interior combinations

name	size W x D x H mm	max load kg	order No
Drawer 100/100, for 400 deep cabinet	903 x 347 x 107	30	834 513-35
Drawer 100/100, for 500 deep cabinet	904 x 347 x 107	30	834 514-35
(A) Middle divider and middle plates			834 507-35
(B) Middle divider and middle plates			834 508-35
(C) Middle divider and middle plates			834 509-35
(D) Pick up boxes			834 512-00

Shelves

name	size W x D mm	max load kg	order No
Shelf	800 x 300	150	852 235-35
Shelf	800 x 400	150	852 234-35
Shelf	1000 x 300	150	852 175-35
Shelf	1000 x 400	150	852 231-35
Shelf	1000 x 500	150	852 185-35
Shelf	1000 x 600	150	852 187-35

Shelf dividers

name	size D x H mm	order No
Pair of steel dividers	190 x 285	861 116-35
Shelf divider 300	300 x 180	852 613-35
Shelf divider 300	300 x 260	852 614-35
Shelf divider 300	300 x 370	852 615-35
Shelf divider 400	400 x 180	832 839-35
Shelf divider 400	400 x 260	832 847-35
Shelf divider 400	400 x 370	832 855-35
Shelf divider 500	500 x 260	852 271-35
Shelf divider 500	500 x 370	852 273-35
Shelf divider 600	600 x 260	852 797-35
Shelf divider 600	600 x 370	852 798-35

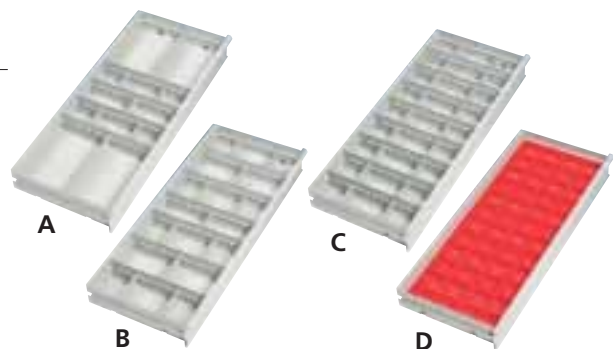



Heavy Storage System

The heavy storage system is suitable for large and heavy items. The shelf load capacity is 400 kg and the shelf depth is 70 cm. It can be built as a

combination of cabinets, drawers and shelves. The storage system comes in one standard height of 200 cm and two widths: 75 cm and 95 cm.

All standard and extension parts include 6 shelves



Standard parts

name	size W x D x H mm	order No
Standard part, open	750 x 714 x 2000	C 375 35 001
Standard part, closed*	750 x 714 x 2000	C 376 35 001
Standard part, open	950 x 714 x 2000	C 395 35 001
Standard part, closed*	950 x 714 x 2000	C 396 35 001

*The standard part, closed, includes back sheet and closed ends.

Extension parts

name	size W x D x H mm	order No
Extension part, open	705 x 714 x 2000	C 377 35 001
Extension part, closed*	705 x 714 x 2000	C 378 35 001
Extension part, open	905 x 714 x 2000	C 397 35 001
Extension part, closed*	905 x 714 x 2000	C 398 35 001

*The standard part, closed, includes back sheet and closed ends.

The W x D x H rule

All our dimensions follow a WDH rule, where the first dimension is the width (W), the middle the depth (D), and the last the height (H).

Load capacity

2000 kg/part

width 750 mm



400 kg/shelf

width 950 mm



350 kg/shelf



Heavy Storage System combinations



95/200-1

C 395 35 001

qty	name	size mm	order No
2	End frame/open	714 x 2000	851 655-35
6	Shelf 90	860 x 714	851 663-35
1	Cross support pair		851 671-35



75/200-2

C 377 07 002

qty	name	size mm	order No
2	Base/top 70	660 x 714	851 656-35
1	Back sheet 70	740 x 1990	851 700-35
2	End frame/closed	714 x 2000	852 449-35
5	Shelf 70	660 x 714	851 658-35
1	Door pair	700 x 2000	854 400-07



75/200-8

C 399 07 008

qty	name	size mm	order No
1	Locking shelf	660 x 714	851 657-35
1	End frame/open	714 x 2000	851 655-35
4	Base/top 70	660 x 714	851 656-35
7	Shelf 70	660 x 714	851 658-35
1	Locking element		851 675-35
2	End frame/closed	714 x 2000	852 449-35
3	Drawer 70/50	612 x 612 x 50	833 967-07
2	Drawer 70/100	612 x 612 x 100	833 975-07
2	Drawer 70/150	612 x 612 x 150	833 983-07
1	Drawer 70/250	612 x 612 x 250	833 991-07
1	Back sheet 70	740 x 1990	851 700-35



75/200-9

C 399 07 009

qty	name	size mm	order No
1	Locking shelf	660 x 714	851 657-35
4	Base/top 70	660 x 714	851 656-35
7	Shelf 70	660 x 714	851 658-35
3	End frame/closed	714 x 2000	852 449-35
3	Drawer 70/50	612 x 612 x 50	833 967-07
2	Drawer 70/100	612 x 612 x 100	833 975-07
2	Drawer 70/150	612 x 612 x 150	833 983-07
1	Drawer 70/250	612 x 612 x 250	833 991-07
2	Back sheet 70	740 x 1990	851 700-35
1	Door pair	700 x 2000	854 400-07
1	Locking element		851 675-35



The Sovella Heavy Storage System includes a wide range of different parts which can be used to create a fully tailor-made solution.

Combination name

95/200-1
 Width cm Height cm Version

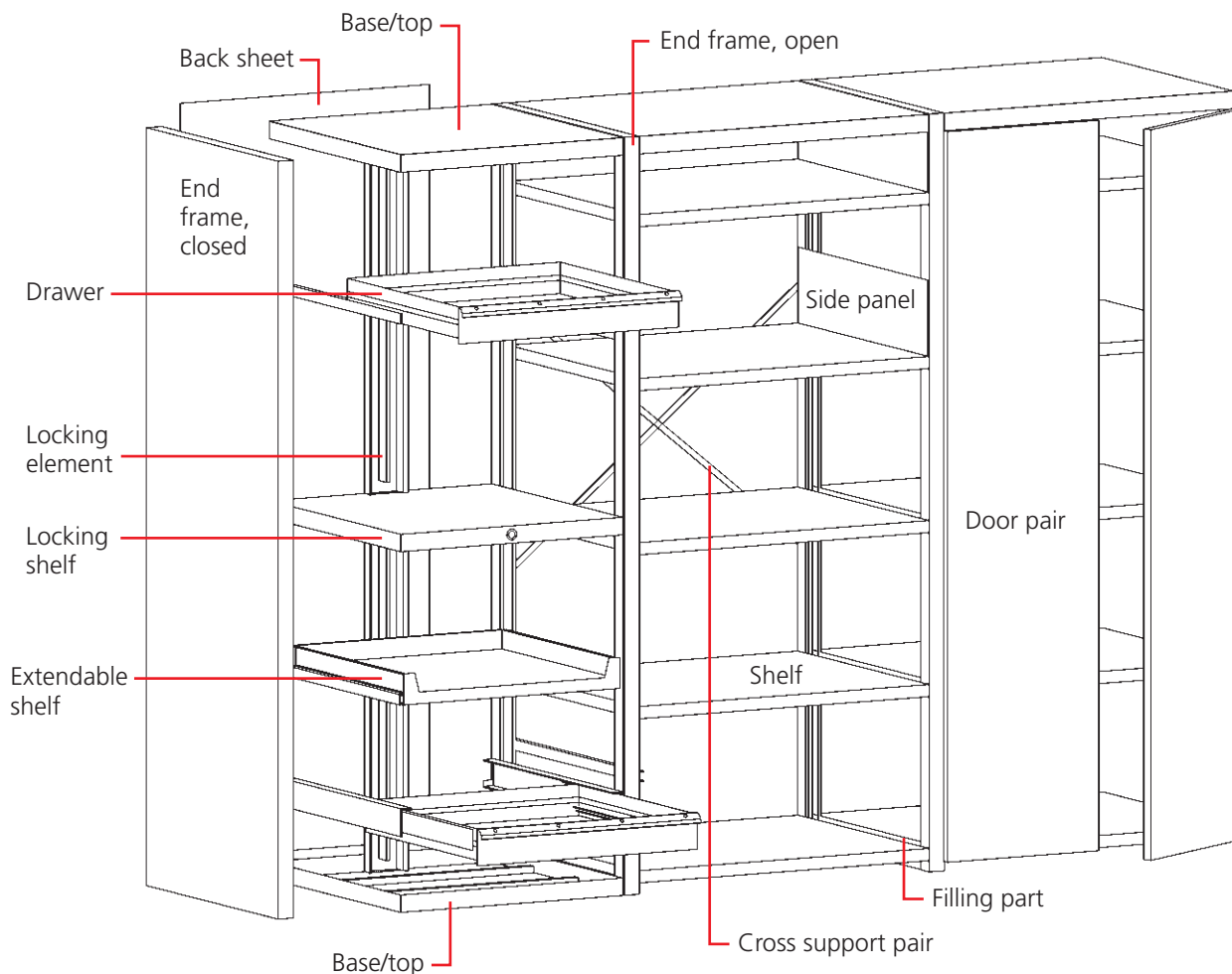

Heavy storage system components

name	size mm	max load kg	order No
End frame/open	714 x 2000		851 655-35
End frame/closed	714 x 2000		852 449-35
Base/top 70	660 x 714		851 656-35
Base/top 90	860 x 714		852 571-35
Cross support pair			851 671-35
Back sheet 70	740 x 1990		851 700-35
Back sheet 90	940 x 1990		851 753-35
Shelf 70	660 x 714	400	851 658-35
Shelf 90	860 x 714	350	851 663-35
Side panel	200 x 700		851 669-35
Filling part	40 x 620		851 670-35
Door pair*	700 x 2000		854 400-07
Extended door pair*	700 x 2000		854 404-07
Door pair*	900 x 2000		854 402-07
Extended door pair*	900 x 2000		854 405-07
Locking shelf 70*	660 x 714		851 657-35
Locking shelf 90*	860 x 714		851 710-35
Locking element	1000		851 675-35

*Door/locking shelf equipped with lock

Heavy storage system drawers

name	size W x D x H mm	effective height mm	max load kg	opens %	order No
Drawer 70/50	612 x 612 x 50	35	80	85	833 967-07
Drawer 70/75	612 x 612 x 75	60	80	85	833 401-07
Drawer 70/100	612 x 612 x 100	85	80	85	833 975-07
Drawer 70/100, 100 % opening	612 x 612 x 100	85	150	100	852 123-07
Drawer 70/125	612 x 612 x 125	110	80	85	833 320-07
Drawer 70/150	612 x 612 x 150	135	80	85	833 983-07
Drawer 70/150, 100 % opening	612 x 612 x 150	135	150	100	852 124-07
Drawer 70/250	612 x 612 x 250	235	80	85	833 991-07
Drawer 70/250, 100 % opening	612 x 612 x 250	235	150	100	852 125-07
Drawer 90/75	860 x 612 x 75	49	80	85	854 262-07
Drawer 90/100	860 x 612 x 100	74	80	85	854 246-07
Drawer 90/150	860 x 612 x 150	124	80	85	854 248-07
Drawer 90/250	860 x 612 x 250	224	80	85	854 249-07
Extendable shelf 70	612 x 612 x 85		80	85	833 843-07
Extendable shelf 70, 100 % opening	612 x 612 x 85		150	100	852 168-07



Industrial shelving and cabinets

Industrial cabinets

A versatile storage solution can be created using the appropriate accessories. An open shelf is not always the best storage method. Tools, expensive

equipment and small items need a different type of solution. Sovella Industrial Cabinets include a wide range of accessories for tool storage.



Industrial cabinet combinations



55/100-1 C 301 07 001

qty	name	order No
1	Cabinet frame 55/100	C 301 07 000
2	Steel shelf 55	854 349-35



80/100-1 C 305 07 001

qty	name	order No
1	Cabinet frame 80/100	C 305 07 000
2	Steel shelf 80	854 345-35



80/100-2 C 305 07 002

qty	name	order No
1	Cabinet frame 80/100	C 305 07 000
2	Steel shelf 80	854 345-35
1	Drawer 80	854 346-35

Practical!

100 cm high cabinet tops have a back stop and rubber mat to be used as an additional work top.



Combination name

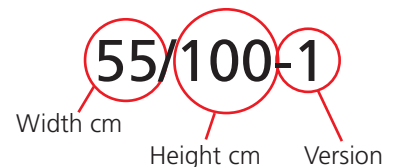



Computer cabinet

Sovella computer cabinet protects equipment from dust and dirt, even in the most demanding conditions. The computer cabinet is pressurised and equipped with an air filter that keeps the dust out. A screen up to a maximum size of 19" will fit in the computer cabinet.



Computer cabinets

name	size W x D x H	order No
Computer cabinet	800 x 500 x 1600	854 358-35
Computer cabinet (without the energy rail)	800 x 500 x 1600	854 364-35



55/160-1 C 303 07 001

qty	name	order No
1	Cabinet frame 55/160	C 303 07 000
3	Steel shelf 55	854 349-35



80/160-1 C 307 07 001

qty	name	order No
1	Cabinet frame 80/160	C 307 07 000
3	Steel shelf 80	854 345-35



80/160-2 C 307 07 002

qty	name	order No
1	Cabinet frame 80/160	C 307 07 000
2	Steel shelf 80	854 345-35
4	Suspension rail, M750	846 450-35
21	Plastic container 9075	851 623-00
5	Container, 9074	851 622-00



80/160-3 C 307 07 003

qty	name	order No
1	Cabinet frame 80/160	C 307 07 004
3	Steel shelf 80	854 345-35
1	Extendable shelf 80	854 347-35

More space for tools

A much larger amount of space is available for storing tools if the perforated wall panel 854 353-07 is installed on the door or side wall of cabinet 80.

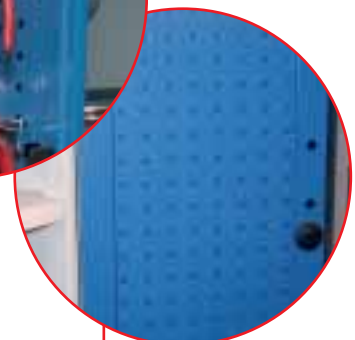
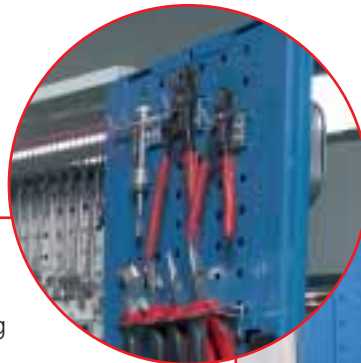



Industrial shelving and cabinets



80/200-1 C 309 07 001

qty	name	order No
1	Cabinet frame 80/200	C 309 07 000
4	Steel shelf 80	854 345-35



80/200-2 C 309 07 002

qty	name	order No
1	Cabinet frame 80/200	C 309 07 000
2	Drawer 80	854 346-35
2	Steel shelf 80	854 345-35
5	Plastic container 9074	851 622-00
1	Suspension rail, M750	846 450-35
1	Extendable shelf 80	854 347-35
1	Perforated panel 736 x 640	835 633-07
2	Perforated panel 288 x 712	854 353-07
1	Pair of support feet	864 730-35

Move with a pallet truck

The cabinet can be moved with a pallet truck or a forklift when the plinth front panel has been removed. Cabinets are equipped with adjustment screws.

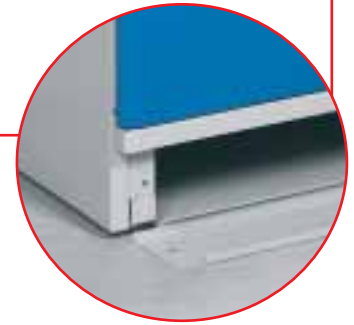

80/200-3 C 309 07 003

qty	name	order No
1	Cabinet frame 80/200	C 309 07 000
2	Drawer 80	854 346-35
2	Steel shelf 80	854 345-35
3	Shelf divider H 370/400	832 855-35
1	Perforated panel 736 x 640	835 633-07
1	Extendable shelf 80	854 347-35
1	Pair of support feet	864 730-35
1	Pair of steel dividers	861 116-35
1	Drawer for suspension folders	854 348-35



80/200-4 C 309 07 004

Includes 2 pcs steel shelves 80 , 854 345-35.

An extendable shelf for the cabinet

When the cabinet is used for storing folders, a separate extending shelf is a good idea. This shelf makes it easy to browse through the folders.





Industrial cabinet accessories



Cabinet frames

name	size W x D x H mm	order No
Cabinet 55/100	550 x 425 x 1000	C 301 07 000
Cabinet 80/100	800 x 425 x 1000	C 305 07 000
Cabinet 55/160	550 x 425 x 1600	C 303 07 000
Cabinet 80/160	800 x 425 x 1600	C 307 07 000
Cabinet 80/160, half doors	800 x 425 x 1600	C 307 07 004
Cabinet 80/200	800 x 425 x 2000	C 309 07 000

Accessories for cabinets

name	size W x D x H mm	max load kg	order No
Perforated panel for the door or side wall	290 x 740		854 353-07
Perforated panel for the back wall M500	468 x 389		860 951-35
Perforated panel for the back wall M750	736 x 640		835 633-07/35
Perforated panel for the back wall M750	736 x 1003		835 641-07/35
Pair of steel dividers	1 x 285 x 190		861 116-35
Steel shelf 55	545 x 391 x 32	100	854 349-35
Steel shelf 80	745 x 396 x 32	100	854 345-35
Shelf divider	1 x 400 x 180		832 839-35
Shelf divider	1 x 400 x 260		832 847-35
Shelf divider	1 x 400 x 370		832 855-35
Extendable shelf 80	725 x 362 x 42	30	854 347-35
Drawer 55	475 x 362 x 90	30	854 344-35
Drawer 80	725 x 362 x 90	30	854 346-35
Drawer for suspension folders	724 x 350 x 240	30	854 348-35
Pair of support feet	40 x 220 x 6		864 730-35
Suspension rail	742 x 90	50	846 450-35

All the M750 accessories fit the cabinet 80 and can be easily installed inside.

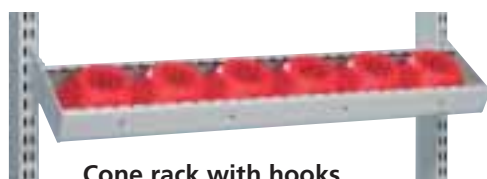

Cone rack with hooks

Cone rack with hooks HSK, Capto, ISO

name	size W x D x H mm	order No
Cone rack with hooks	742 x 188 x 90	854 430-35



Bit holder

Bit holders M750

name	hole Ø mm	holes pcs	order No
Bit holder 1	12,5	39	852 318-51
Bit holder 2	17	29	852 319-51
Bit holder 3	24	21	852 320-51
Bit holder 4	30	12	852 321-51

Tool brackets

name	rack with hooks can hold pcs	order No
ISO 50	8	837 770-00
HSK 40A/50B	9	854 215-00
HSK 63A/80B	7	854 217-00
HSK 100A/125B	7	854 219-00
Capto C4	9	854 201-00
Capto C5	9	854 202-00
Capto C6	6	854 203-00



Perforated panels

Perforated panels are a part of a good organisation

Perforated panels are efficient dividers of space and, at the same time, practical storage facilities for tools and equipment. An industrial screen can be

used as a sound-insulating space divider through equipping it with perforated back panel elements with fireproof insulation.



Order and tidiness are appreciated

Order and tidiness cannot be achieved and maintained without there being a place for each tool. Perforated panels and the hooks offer a practical and versatile solution for storing tools and equipment. Perforated panel products are available for direct fastening to the wall or for fastening to upright profiles or tubes.

Hooks also for heavy loads

The hooks can withstand loads of up to 20 kg.





Steel shelves, suspension rails, perforated back and wall panels and a perforated panel cabinet can be fastened to the upright profiles.





Perforated panels

Perforated back and wall panels

The perforated back panels are fastened to the upright tubes. The perforated wall panels are attached, either directly to the wall with screws or

to the upright profiles with fastening clips. The size of the perforation is 9 x 9 mm, center to center 38 mm.



1 Perforated back panels

name	module	size W x H mm	order No
Perforated back panel	M500	468 x 389	860 800-35
Perforated back panel	M750	736 x 194	835 625-07
Perforated back panel	M750	718 x 389	860 258-35
Perforated back panel	M750	736 x 640	835 633-35/07
Perforated back panel	M750	736 x 1003	835 641-35/07
Perforated back panel	M750	718 x 613	836 702-35/07
Perforated back panel, insulated	M750	718 x 613	836 700-35/07
Perforated back panel	M900	871 x 389	860 259-35
Perforated back panel 1000		986 x 960	835 676-07

Perforated wall panels fastened to the wall

name	size W x H mm	order No
Perforated wall panel	454 x 988	837 369-07
Perforated wall panel	949 x 988	837 334-07
Perforated wall panel	949 x 1444	837 342-07
Perforated wall panel	949 x 1976	837 350-07

Fastened directly to the wall using screws.

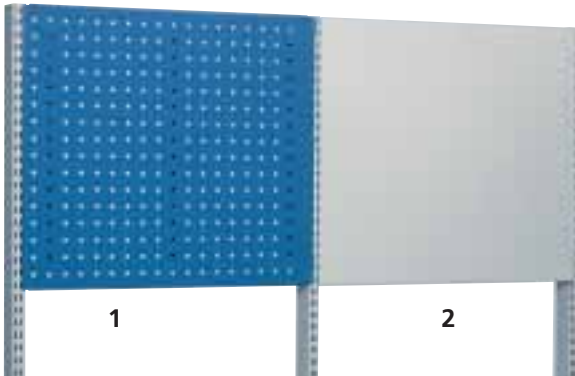

2 Back panels

name	module	size W x H mm	order No
Back panel	M500	485 x 240	860 801-35
Back panel	M500	485 x 400	860 802-35
Back panel	M500	485 x 640	860 803-35
Back panel	M750	735 x 640	835 668-35/07
Back panel	M750	735 x 240	851 891-35
Back panel	M750	735 x 400	851 892-35
Back panel	M900	888 x 400	860 191-35

Back panels are solid, colour light grey ESD 35 (ESD 7035).



The colour code is included in the order number. It is either at the end, following the hyphen (e.g. 860 804-**35**), or in the middle (e.g. 100/40/200 C 334 **07** 000).



Industrial screens

Industrial screens are modular, and they can be equipped with all M750 accessories illustrated from page 30 onward. Industrial screens can be used as

space dividers. They also provide noise insulation; the combinations available have perforated back panels on both sides and one side is insulated.

Industrial screens

name	size W x D x H mm	order No
Standard part, T-foot	780 x 60 x 1850	C 520 07 001
Extension part, T-foot	750 x 560 x 1850	C 520 07 002
Extension part, L-foot	750 x 310 x 1850	C 520 07 003
Extension part, I-foot	750 x 60 x 1850	C 520 07 004

Includes 6 perforated back panels, 3 pcs/side.

The standard part includes two feet.

The extension part includes one foot.

Part list

name	size W x D x H mm	order No
T-foot	1850	836 516-35
L-foot	1850	836 532-35
I-foot	1850	836 597-35
Spacer bar	750	835 838-35
Corner joint pair		847 615-51
Perforated back panel M750	718 x 17 x 613	836 702-35/07
Perforated back panel M750, insulated*	718 x 17 x 613	836 700-35/07
Upper list	718 x 65	851 907-07

The wall module requires two spacer bars.

* The insulation material used is polyether foam.

All M750 accessories are suitable for the industrial screen.



The colour code is included in the order number. It is either at the end, following the hyphen (e.g. 860 804-**35**), or in the middle (e.g. 100/40/200 C 334 **07** 000).

Tool storage system

The original Sovella tool storage system requires only 2 m² of floor space and provides 16 m² of storage space. There is no need to fasten it to the floor, as it stands firmly on its own. There is a wheel on the lower edge of the panels which makes them easy to move. The load capacity is 100 kg/panel. A maximum of 10 panels can be fastened to the tool storage system.

Tool storage system

name	size W x D x H mm	order No
Tool storage system, 4 panels	1025 x 1035 x 2125	830 518-07
Additional panel	15 x 949 x 1976	830 682-07





Perforated panels

Sovella R-hooks

Our selection includes more than 50 different kinds of hooks and brackets for the efficient storage and

organisation of tools. All the hooks and brackets can be easily attached to our perforated panels.



R1



R2



R3



R10



R13

Hook R1

name	L	Ø	max load kg	order No
Hook R1	30	3	20	853 207-51
Hook R1	50	4	15	853 208-51
Hook R1	50	6	20	853 241-51
Hook R1	80	6	20	853 209-51
Hook R1	100	4	8	853 210-51
Hook R1	100	6	15	853 211-51
Hook R1	150	4	4	853 212-51
Hook R1	150	6	10	853 213-51
Hook R1	200	4	2	853 214-51
Hook R1	200	6	6	853 215-51
Hook R1	300	6	3	853 216-51
Hook R1	300	8	8	853 217-51

L = hook length mm

All order numbers include 5 pcs.

Hook R2

name	L	Ø	A	max load kg	order No
Hook R2	33	3	17	15	853 218-51
Hook R2	43	4	25	15	853 219-51
Hook R2	43	4	40	15	853 220-51
Hook R2	100	6	25	15	853 221-51
Hook R2	150	4	15	6	853 222-51
Hook R2	150	6	25	15	853 223-51
Hook R2	200	6	25	10	853 224-51

L = hook length mm

A = free gap mm

All order numbers include 5 pcs.

Hook R3

name	L	Ø	max load kg	order No
Hook R3	10	6	20	853 225-51
Hook R3	50	6	20	853 226-51

L = hook length mm

All order numbers include 5 pcs.

Hook R10

name	L	A	max load kg	order No
Hook R10	28	9	15	853 227-51
Hook R10	33	17	10	853 228-51

L = hook length mm

A = free gap mm

All order numbers include 5 pcs.

Hook R13

name	L	Ø	max load kg	order No
Hook R13	157	3	1	853 229-51

L = hook length mm

All order numbers include 5 pcs.

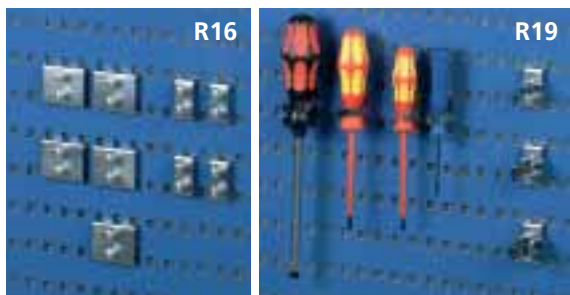

R16

R19

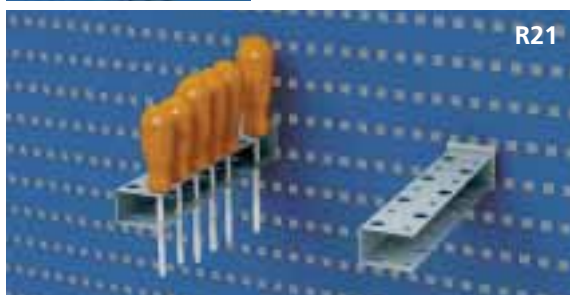

R21



R24



R26



R29

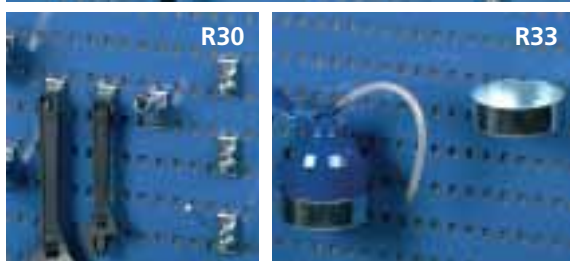

R30

R33

Hook R16

name	L	max load kg	order No
Hook R16	20	20	831 514-51
Hook R16	46	20	831 506-51

L = hook length mm

All order numbers include 1 pcs.

Hook R19

name	Ø	order No
Hook R19	5	853 230-51
Hook R19	13	853 231-51
Hook R19	19	853 232-51
Hook R19	22	853 233-51

All order numbers include 5 pcs.

Hook R21

name	L	Ø	order No
Hook R21	220	12	831 646-51

L = hook length mm

All order numbers include 1 pcs.

Hook R24

name	L	Ø	order No
Hook R24	65	17	831 700-51
Hook R24	80	26	831 719-51
Hook R24	100	42	852 167-51

L = hook length mm

All order numbers include 1 pcs.

Hook R26

name	L	max load kg	order No
Hook R26	160	15	838 896-51

L = hook length mm

All order numbers include 1 pcs.

Hook R29

name	L	max load kg	order No
Hook R29	40	5	853 234-51
Hook R29	60	5	853 235-51
Hook R29	80	10	853 236-51

L = hook length mm

All order numbers include 5 pcs.

Hook R30

name	L	Ø	max load kg	order No
Hook R30	35	4	20	853 237-51
Hook R30	85	6	20	853 238-51

L = hook length mm

All order numbers include 5 pcs.

Hook R33

name	H	Ø	order No
Hook R33	30	90	832 162-51

H = hook height mm



Perforated panels



R35



R37



R41



R42

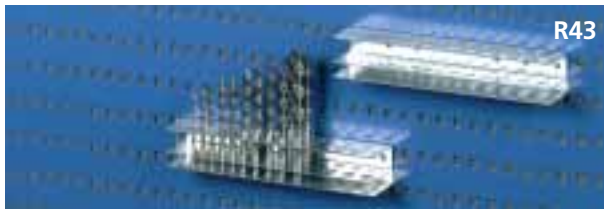

R43

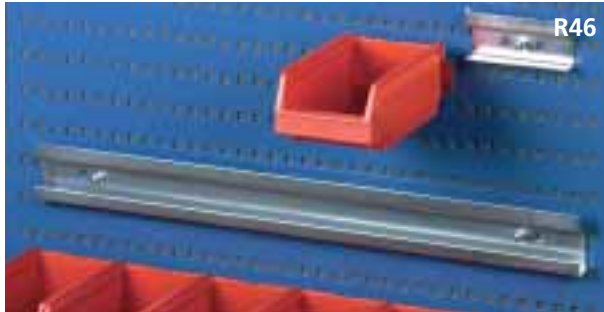

R46



R47



R48



Hook R35

name	L	A	order No
Hook R35	17	35	853 239-51
Hook R35	17	55	853 240-51

L = hook length mm

A = free gap mm

All order numbers include 5 pcs.

Hook R37

name	Ø	max load kg	order No
Hook R37	40	20	831 433-51
Hook R37	60	20	831 441-51
Hook R37	80	15	831 603-51

All order numbers include 1 pcs.

Hook R41

name	L	order No
Hook R41	556	838 357-51

L = hook length mm

All order numbers include 1 pcs.

Hook R42

name	L	order No
Hook R42	238	838 365-51

L = hook length mm

All order numbers include 1 pcs.

Hook R43

name	L	order No
Hook R43	238	838 373-51

L = hook length mm

All order numbers include 1 pcs.

Hook R46

name	L		order No
Hook R46	112	for plastic containers 9075 and 9080	831 794-51
Hook R46	634	suspension rail for six plastic containers 9075 and 9080	839 086-51

L = hook length mm

All order numbers include 1 pcs.

Hook R47

name	W x D	max load kg	order No
Hook R47	350 x 120	4	831 654-35

All order numbers include 1 pcs.

Hook R48

name	W x D x H	order No
Hook R48	240 x 70 x 465	838 380-51

All order numbers include 1 pcs.

Paper roll holder

name	L	order No
Paper roll holder	300	854 043-35

L = max roll width mm



Box holder



Utility box



Folder compartment

Other supplies

name	size W x D x H mm	max load kg	order No
Box holder for four pick up boxes	456 x 165 x 48	5	854 042-35
Utility box	410 x 155 x 90	4	854 041-35
Folder compartment	466 x 90 x 240	4	854 040-35



Hook sets

Ready-made hook sets help you to get started.

Choose the most suitable hook set for your needs from the following possibilities:

- Hook set 1** Basic light hook set
- Hook set 2** Basic hook set for hand tools
- Hook set 3** Hook set for perforated tool cabinet
- Hook set 4** All inclusive set for hand tools
- Hook set 5** Hook set for heavy tools in perforated tool cabinet



Hook sets

Hooks included in the sets	L mm	Ø mm	A mm	Hook sets				
				set 1 835 110-51	set 2 835 102-51	set 3 834 690-51	set 4 834 650-51	set 5 852 705-51
R1	30	3		6	5	17	10	10
R1	50	4		2	5		10	10
R1	100	6		2	2			10
R2	33	3	17	2	3	4	4	5
R2	43	4	25			1	3	5
R2	43	4	40	2	3	2	2	5
R3	50				2			
R10	28		9	1	2			5
R10	33		17	1	2			5
R19		5		1			5	
R19		13		2	2	2	5	5
R19		19		2	2		1	5
R19		22		1	2			5
R21	220	12			1			1
R24	65	17			1	5	7	3
R24	80	26				1	2	3
R29	40			1		2	2	2
R29	80				1			2
R29	60				1			2
R30	35	4			5	32	37	10
R33	30	90			1	1	2	1
R35	17		35	2	2	1	6	5
R35	17		55	1	1	2	1	5
R37		60			1		3	3
R42	35		238		1	1	1	1
R43	42		238			1		
Pieces				26	45	72	101	108



MultiLine assembly solutions

Material flow to effective workstations

In the assembly industry, workstations are well planned and designed since they must function as well as possible. MultiLine is expressly designed as an accessory for Sovella workspace solutions.

Its underlying concept is simple: by connecting workstations to a transfer line you can achieve a more flexible and controllable material flow between workstations without sacrificing characteristics such as usability or ergonomics.



Low investment costs

The MultiLine transfer system has two characteristics, due to which its investment costs remain low. Firstly, it is integrated with an existing system, complementing current processes and thereby avoiding the need for additional investments.

Secondly, it is built using standard parts and design, which makes it easy to adapt to any situation and space. It can also be easily and quickly modified when the layout changes.





Optimised for WIP

The core of WIP logic (work in process) comprises allocating a value to stored items between production phases. Money is wasted when half-ready products or components lie unused e.g. in a trolley used as a buffer. If MultiLine is used, only a small quantity of half-finished products lies waiting between production phases.

This problem is amplified if a mistake made in one phase remains unnoticed until a trolley full of defective components is brought to the next phase. With MultiLine both the cost per mistake and the number of mistakes are significantly minimised, because only a few faulty products can be produced before the mistake is noticed.



For a tailor-made study, contact our specialists in lean manufacturing.

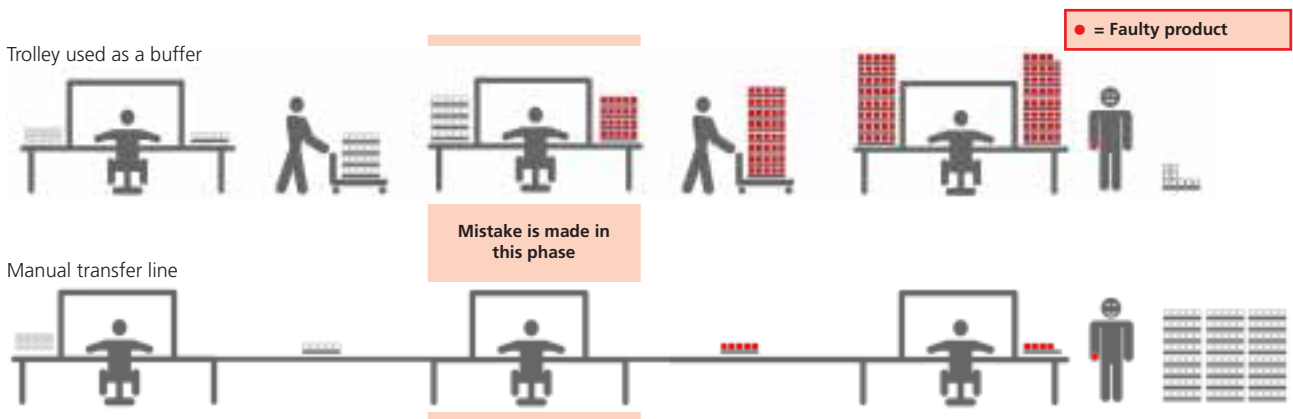



Sovella wall shelving

Sovella wall shelving

Sovella wall shelving is an easily modified, versatile shelving system. It is mounted directly on the wall. Keeping floor area clean and empty is important,

especially in public buildings. The wall-mounted Sovella shelving is particularly suitable for public buildings and laboratories.

The wall-mounted Sovella shelving with accessories is a practical storage system that makes facilities easy to keep clean. Keeping floor area clean and empty is important, especially in public buildings.



Sovella wall shelving is perfect for public buildings and also for laboratory use. The horizontal rail eases installation and modification of the shelving system.



The wall mounted shelving system is also available in stainless steel.



Oval horizontal rail

We recommend the oval horizontal rail for very heavy loads (300 kg/metre)





Sovella wall shelving combinations

In order to furnish large spaces in public buildings quickly, you can choose a base section and add as many extensions as you need. The combinations are

available in 900 mm wide, with three or five shelves. The combinations come in white (colour code 21) and light grey (colour code 35).

Base section 1500/3, 3 shelves

module	size W x D x H mm	max load kg/shelf	order No (white)	order No (light grey)
M900	M900 x 300 x 1500	35	C 404 21 023	C 404 35 023
M900	M900 x 400 x 1500	35	C 404 21 024	C 404 35 024

Extension section 1500/3, 3 shelves

module	size W x D x H mm	max load kg/shelf	order No (white)	order No (light grey)
M900	M900 x 300 x 1500	35	C 404 21 123	C 404 35 123
M900	M900 x 400 x 1500	35	C 404 21 124	C 404 35 124



Base section 1500/3



Extension section 1500/3

Base section 2000/5, 5 shelves

module	size W x D x H mm	max load kg/shelf	order No (white)	order No (light grey)
M900	M900 x 300 x 2000	35	C 405 21 023	C 405 35 023
M900	M900 x 400 x 2000	35	C 405 21 024	C 405 35 024

Extension section 2000/5, 5 shelves

module	size W x D x H mm	max load kg/shelf	order No (white)	order No (light grey)
M900	M900 x 300 x 2000	35	C 405 21 123	C 405 35 123
M900	M900 x 400 x 2000	35	C 405 21 124	C 405 35 124



Base section 2000/5



Extension section 2000/5



Sovella wall shelving part list

Direct wall fastening

Fasten the upright profiles to the wall with screws, using fasteners suitable for the wall material.

Horizontal rail fastening

Fasten the oval horizontal rail at an appropriate height. Take the wall's inner structure into account.

Fasten the upright tubes to the oval horizontal rail. The horizontal rail makes it easy to install and modify the system.

Select accessories

Shelves, brackets and perforated back panels are attached to the upright profiles.

Colours

Sovella wall shelving parts are available in white (-21) and light grey (-35). Other colours are available on request.

Oval horizontal rail

name	size mm	order No
1a Oval horizontal rail	2000	010 013-35
1b Upright tube for the oval horizontal rail	1200	100 071-35
Upright tube for the oval horizontal rail	2000	100 070-35
Extension piece for the oval horizontal rail		110 913-51

Upright profiles

name	size mm	order No
2 Upright profile	150	001 546-35
Upright profile	500	001 554-35
Upright profile	1000	001 589-35
Upright profile	1500	001 597-35
Upright profile	2000	001 619-35
Upright profile	2250	110 943-35
Upright profile	2500	001 627-35

Brackets

name	size mm	max load kg	order No
3 Bracket	200	100	001 988-35
Bracket	250	80	001 996-35
Bracket	300	70	002 003-35
Bracket	350	60	002 011-35
4 Bracket, strengthened	400	120	001 678-35
Bracket, strengthened	450	100	001 686-35
Bracket, strengthened	500	80	001 694-35
Bracket, strengthened	550	70	001 708-35

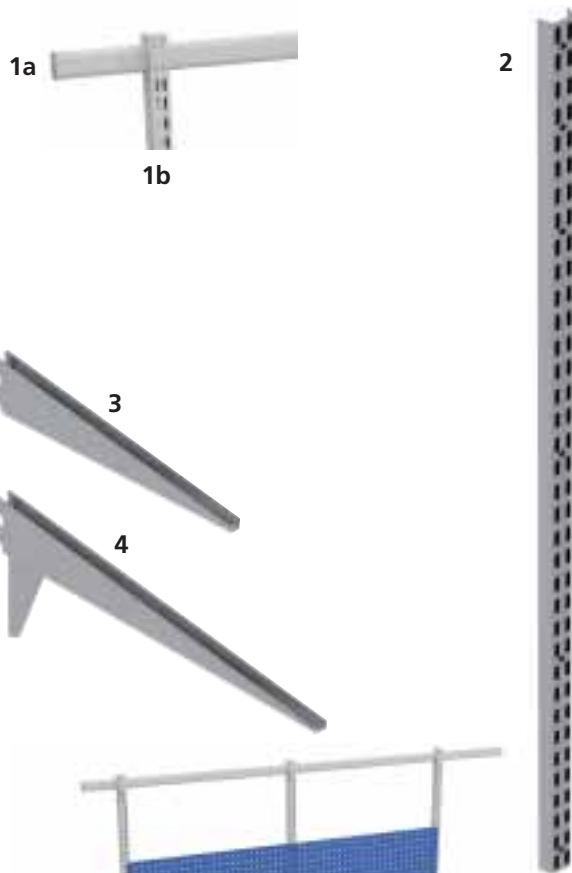

Cupboard fixings, see page 99.



In this example an oval horizontal rail and upright tubes have been fitted to the wall above a fixed cable duct to accommodate the accessories.



Shelves

	name	size mm	max load kg	order No
5	Steel shelf	900 x 200	30	010 087-35
	Steel shelf	900 x 250	30	010 088-35
	Steel shelf	900 x 300	35	010 070-35
	Steel shelf	900 x 400	40	010 071-35
	Steel shelf	900 x 500	40	010 072-35
	Steel shelf	900 x 550	35	110 959-35
	Steel shelf with a fixed support	900 x 600	50	010 073-35
6	Support for the steel shelf	900		009 164-35

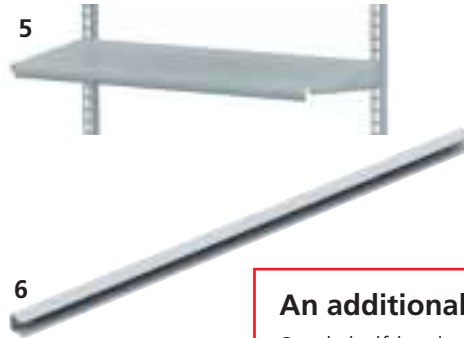

An additional support

Steel shelf load capacity can be doubled with an additional support for the steel shelf (009 164-35).



Cupboard fixings

	name	order No
7	Cupboard fixing bracket, top with flange right	010 114-35
	Cupboard fixing bracket, top with flange left	010 115-35
	Cupboard fixing bracket, bottom/top right	010 112-35
8	Cupboard fixing bracket, bottom/top left	010 113-35

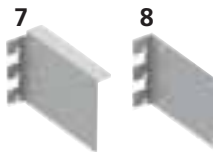

For example, wooden cupboards can be fastened to the upright profiles with fixing brackets. In that case you do not need to make any holes to the wall.

Perforated back panels

	name	size mm	order No
9	Perforated back panel	900 x 300	006 378-35
	Perforated back panel	900 x 610	557 471-35
	Perforated back panel	900 x 810	557 498-35

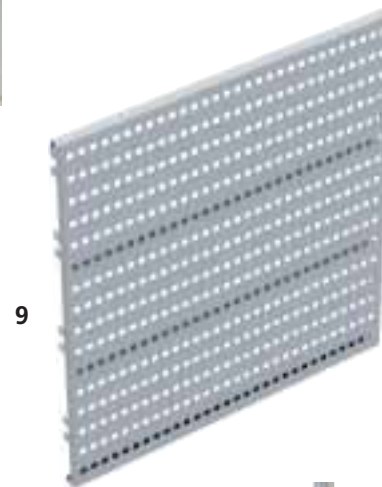

Stainless steel shelving system

	name	size mm	max load kg	order No
	Upright profile, stainless steel	1000		111 032-55
	Upright profile, stainless steel	2000		111 034-55
	Pair of bracket, stainless steel	300	120	111 023-55
	Pair of bracket, stainless steel	400	120	111 024-55
	Stainless steel shelf	900 x 300	35	111 003-55
10	Stainless steel shelf	900 x 400	40	111 004-55



Perforated panels and R-hooks: see pages 88-93.





Spare parts

Cabinet spare parts

name	product	order No
Rubber mat 550 x 420	Industrial cabinet 55/100	836 716-00
Rubber mat 799 x 420	Industrial cabinet 80/100	836 715-00
Fan with filter EU	Computer cabinet	900 550-00
Fan with filter US	Computer cabinet	900 554-00

Drawer unit spare parts

name	product	order No
Ball race rail pair	L-38 and L-45 drawer units	943 571-00
Ball race rail pair	38, 45 and 75 drawer units	944 570-00
End cap for drawer handle, pair	38, 45, 55, 70, 71, 90 and 130 drawer units	900 104-00
Cover with rubber mat, ESD	45 drawer unit	872 242-35
Shelf for cabinet version	45 drawer unit	872 043-35
Bracket pair for the shelf	45 and 75 drawer units	872 045-51
Cover with rubber mat, ESD	75 drawer unit	872 243-35
Shelf for cabinet version	75 drawer unit	872 044-35
Wheel set Ø 100 ESD	45 and 75 drawer units	852 774-00

Sliding rail, left	55, 70, 90 and 130 drawer units	852 121-00
Sliding rail, right	55, 70, 90 and 130 drawer units	852 120-00

Drawer unit frame	55/37 drawer unit	854 111-35
Drawer unit frame	55/66 drawer unit	854 099-35
Base	55 drawer unit	854 101-35
Wheel set Ø 100	55 drawer unit	852 625-00
Top cover	55 drawer unit	854 102-35
Rubber mat 549 x 709	55 drawer unit's cover	836 717-00
Drawer 55/50	55 drawer unit	854 120-07
Drawer 55/100	55 drawer unit	854 121-07
Drawer 55/150	55 drawer unit	854 122-07
Drawer 55/250	55 drawer unit	854 123-07
Extendable shelf	55 drawer unit	854 106-35
Shelf (including brackets)	55 drawer unit	854 114-35
Drawer unit frame (base included)	70/110 drawer unit	851 734-35
Drawer unit frame (base included)	70/140 drawer unit	851 736-35
Sliding-door cabinet frame	70/110 sliding-door cabinet	852 272-35
Cover with rubber mat	70 drawer unit	834 904-41
Cover with rubber mat	Sliding-door cabinet	852 276-41
Drawer 70/50	70 drawer unit	833 967-07
Drawer 70/75	70 drawer unit	833 401-07
Drawer 70/100	70 drawer unit	833 975-07
Drawer 70/100, telescopic	70 drawer unit	852 123-07
Drawer 70/125	70 drawer unit	833 320-07
Drawer 70/150	70 drawer unit	833 983-07
Drawer 70/150, telescopic	70 drawer unit	852 124-07
Drawer 70/250	70 drawer unit	833 991-07
Drawer 70/250, telescopic	70 drawer unit	852 125-07
Extendable shelf	70 drawer unit	833 843-07
Extendable shelf, telescopic	70 drawer unit	852 168-07
Drawer unit frame (base included)	71/79 drawer unit	854 001-07
Rubber mat 676 x 445	71/79 drawer unit's cover	854 036-00
Drawer 71/75	71/79 drawer unit	854 025-07
Drawer 71/100	71/79 drawer unit	854 026-07
Drawer 71/125	71/79 drawer unit	854 027-07
Drawer 71/250	71/79 drawer unit	854 028-07
Drawer unit frame (base included)	90/110 drawer unit	854 250-35
Drawer unit frame (base included)	90/140 drawer unit	854 251-35
Cover with rubber mat 906 x 736	90 drawer unit	854 258-41
Drawer 90/75	90 drawer unit	854 262-07
Drawer 90/100	90 drawer unit	854 246-07
Drawer 90/150	90 drawer unit	854 248-07
Drawer 90/250	90 drawer unit	854 249-07



Drawer unit frame (base included)	130/110 drawer unit	854 252-35
Drawer unit frame (base included)	130/140 drawer unit	854 253-35
Cover with rubber mat 1304 x 736	130 drawer unit	854 259-41
Drawer 130/75	130 drawer unit	854 263-07
Drawer 130/100	130 drawer unit	854 242-07
Drawer 130/150	130 drawer unit	854 244-07
Drawer 130/250	130 drawer unit	854 245-07

Drawer interior spare parts

name	product	order No
Divider H=100, lateral	45/100 drawer	872 950-35
Divider H=100, lateral	75/100 drawer	872 952-35
Divider H=150, lateral	45/150 drawer	872 951-35
Divider H=150, lateral	75/150 & 200 drawers	872 953-35
Divider holder, side wall	45 and 75 drawers	872 960-35
Divider H=75, longitudinal	71/75 drawer	835 413-35
Divider H=100, longitudinal	71/100 drawer	835 412-35
Divider H=100, longitudinal	75/100 drawer	872 954-35
Divider H=150, longitudinal	75/150 drawer	872 955-35
Divider holder, rear wall	75 drawer	872 961-35
Middle plate L=100, lateral	55/50 and 70/50 drawers	835 323-35
Middle plate L=100, lateral	70/75, 90/75 and 130/75 drawers	832 525-35
Middle plate L=100, lateral	55/100, 70/100, 90/100 and 130/100 drawers	832 528-35
Middle plate L=100, lateral	55/150, 70/150, 90/150 and 130/150 drawers	832 533-35
Middle plate L=150, lateral	55/50 and 70/50 drawers	835 331-35
Middle plate L=150, lateral	70/75, 90/75 and 130/75 drawers	832 526-35
Middle plate L=150, lateral	55/100, 70/100, 90/100 and 130/100 drawers	832 529-35
Middle plate L=150, lateral	55/150 & 250, 70/150 & 250, 90/150 & 250 and 130/150 & 250 drawers	832 531-35
Middle plate L=300, lateral	55/50 and 70/50 drawers	835 404-35
Middle plate L=300, lateral	70/75, 90/75 and 130/75 drawers	832 527-35
Middle plate L=300, lateral	55/100, 70/100, 90/100 and 130/100 drawers	832 530-35
Middle plate L=300, lateral	55/150 & 250, 70/150 & 250, 90/150 & 250 and 130/150 & 250 drawers	832 532-35
Divider H=50, longitudinal	55/50 and 70/50 drawers	832 510-35
Divider H=75, longitudinal	70/75, 90/75 and 130/75 drawers	832 520-35
Divider H=100, longitudinal	55/100, 70/100, 90/100 and 130/100 drawers	832 521-35
Divider H=150, longitudinal	55/150 & 250, 70/150 & 250, 90/150 & 250 and 130/150 & 250 drawers	832 522-35
Divider H=75, lateral	90/75 drawer	854 281-35
Divider H=75, lateral	130/75 drawer	854 280-35
Divider H=100, lateral	90/100 drawer	854 266-35
Divider H=100, lateral	130/100 drawer	854 268-35
Divider H=150, lateral	90/150 & 250 drawers	854 267-35
Divider H=150, lateral	130/150 & 250 drawers	854 269-35
Divider holder H=75, side wall	90/75 and 130/75 drawers	854 282-35
Divider holder H=100, side wall	90/100 and 130/100 drawers	854 264-35
Divider holder H=150, side wall	90/150 & 250 and 130/150 & 250 drawers	854 265-35

Trolley spare parts

name	product	order No
Wheel set Ø 100	Worktop trolley, Storage trolley and Ergo trolley	852 768-00
Wheel set Ø 100	Fitter's trolley	834 734-00
Wheel set Ø 150	Basic trolley	834 742-00
Wheel set Ø 100 ESD	Worktop trolley, Storage trolley and Ergo trolley	852 774-00
Wheel set Ø 100 ESD	Multi trolley	860 429-00
Fixed wheel Ø 150	Service trolley	900 537-00
Fixed wheel Ø 160	Heavy duty trolley	900 040-00
Swivel wheel Ø 100	Service trolley	942 060-00
Swivel wheel Ø 160	Heavy duty trolley	900 041-00

Accessory spare parts

name	product	order No
Wheel set Ø 50	Transport skate	853 176-00
Wheel set Ø 50 ESD	Transport skate ESD	853 175-00
Sliding piece/Tool carrier	Light/Balancer rail and Balancer arm	940 453-00
Arm holder 40	TowerLine	861 098-35
Arm holder 60	TowerLine	861 099-35

	page
Accessories	30
Upright tubes and upright tube modules	31
Lighting and balancer rails	33
Energy rails, pneumatic rails	34
Cable ducts and cable troughs	34
Shelves	35
Accessories with arms	37
Suspension rails	39
Plastic containers	39
Accessories attached to the table top	40
Accessories, ESD	40
Accessories under table top	41
Cone racks	42
Small storage cabinets	42
Containers and pick up boxes	43
Other supplies	43
Accessories for cabinets	85
Accessories for chairs	45
Accessories for trolleys	70, 71, 72, 73
Accessory spare parts	101
Adjustable auxiliary tops	37
Adjustable shelves	35, 69
Aluminium bracket	31
Apparatus stand	38
Armrest	40
Assembly lines	94
Assembly solutions	94
Auxiliary tops	37
Back panels, solid	88
Bag holder for table top	43
Balancer arm	33
Ball race rail pair	100
Bars	41
Base	100
Basic corner table frame	16
Basic extension table frame	16
Basic packaging workstation	15
Basic table tops	17
Basic tables	14
Basic trolley	72
Basic trolley accessories	72
Basic upright frame	15, 16
Basic workstation	15
Basic worktable frame	16
Basic worktables	14
Bottle holder for upright tube	43
Bottom shelf for Multi trolley	69
Box holder for pick up boxes	93
Box stand	38
Bracket pair for the shelf	100
Cabinets, industrial	82
Cable ducts	34
Cable troughs	34
CD/folder box	42
Certificates	7
Chairs	44
Chairs with upholstery	45
Colour stripes	13, 25
Colours	5
Computer cabinet	83
Concept corner table frame	12
Concept crank table	11
Concept extension table frame	12
Concept motor table	11
Concept table colour stripe pair	13
Concept worktable frame	12
Cone rack with base HSK, Capto, ISO	42, 60
Cone racks	42, 60
Containers	43
Cover with rubber mat	100, 101
Curved suspension rail with arm	38
CPU cabinet	41
CPU holders	41
Divider holders	101
Dividers	101
Document holders	37
Document shelf	35
Double arm	37
Drawer interiors for:	
Drawer 45	50
Drawer 75	51
Drawer 55	53
Drawer 71	55
Drawer 70	59
Drawer 90	63
Drawer 130	65

	page
Drawer unit frames	
Drawer unit frames 55	100
Drawer unit frames 70	61, 100
Sliding door cabinet frame 70	61, 100
Drawer unit frames 71	100
Drawer unit frames 90	100
Drawer unit frames 130	101
Drawer unit spare parts	100
Drawer units	47
Drawer units 26 and 35	48
Drawer units 38	48
Drawer units 45	49
Drawer units 75	51
Drawer units 55	52
Drawer unit 55 combinations	54
Drawer units 71	55
Drawer units 70	56
Drawer units 90	62
Drawer units 130	64
Drawers	
Drawers 55	100
Drawers 70 + extendable shelves	61, 100
Drawers 90	100
Drawers 130	101
Drawing holder	56
End cap for drawer handle	100
Energy rails	34
Ergo mat, ESD	40
Ergo trolley	68
Ergonomics	36
ESD protection	6
ESD products	
ESD table tops	13, 25
ESD accessories	40
ESD grounding supplies:	
- Fabric wrist strap	40
- Spiral cord	40
- Wristband junction box	40
- Grounding cord	40
- Grounding junction box	40
ESD mats	40, 100
ESD table mat	40
ESD chairs	45
ESD trolleys	68
Extendable shelf, telescopic	100
Extendable shelves	35, 84, 100
Extendable shelves for drawer unit 70	61
Fabric wrist strap	40
Fan with filter	100
Fastening sets for:	
Drawer unit 26 and 35	48
Drawer unit 38	48
Drawer unit 45	50
Drawer unit 75	51
Drawer unit 55	52
File cabinet	42
Fitter's trolleys	71
Fitter's trolleys accessories	71
Fixed wheel	101
Fixing plastic containers on the suspension rail	39
FlexFlow flow-through shelving	26
FlexFlow combinations	27
FlexFlow shelving, frame supports	29
FlexFlow components	29
FlexFlow roller profiles	29
FlexFlow workstation accessories	29
Foot extension for cone rack with base	42
Footrests	41
Ground junction box	40
Grounding cord	40
Grounding supplies	40
Guarantees	7
Heavy arm	37
Heavy storage system	79
Extension parts	79
Heavy storage system combinations	80
Heavy storage system components	81
Heavy storage system drawers	81
Standard parts	79
Heavy-duty trolley accessories	70
Heavy-duty trolleys	70
Height adjustable arm	37
Height adjustable profile	37
Hooks	86, 90-93
I-foot	89
Industrial cabinets	82

	page
Industrial cabinet accessories	.85
Industrial cabinet combinations	.82
Computer cabinet	.83
Industrial cabinet frames	.85
Industrial screens	.89
Insert for ISO 50 bracket	.42, 60
IT shelves	.37
Keyboard tray and mouse tray for LCD holder	.37
Keyboard tray for LCD holder	.37
Keyboard tray open	.41
Laminate table top	.13, 17, 25
LCD holder	.37
L-foot	.89
Lighting ergonomics	.32
Lights	
Light 1000	.33
Side light 500	.33
Task light	.33
Lighting and balancer rails	.33
Light arm with table top fixing	.37
Light-duty trolleys	.68
Locking system	.7
Lower shelves for the Basic table	.16
Lower shelves for the Workshop table	.20
Middle plate	.54, 101
Monitor shelf	.37
Motorized tilting frame	.13
Multi trolley	.67, 68, 69
MultiLine assembly solutions	.94
Packaging workstation, Basic	.15
Pencil box for drawers 38 and 45	.48
Perforated panels	.86
Perforated back and wall panels	.88
Back panels, solid	.88
Industrial screens	.89
Tool storage system	.89
R-hooks	.90
Perforated tool cabinet	.42
Pick up boxes	.43
Plastic containers	.39
Pneumatic rails	.34
Polyurethane chairs and stools	.45
R-hooks	.90
Racks	.38
Replacement arms	.37
Roll holder for upright tube	.43
Rotating base ESD	.43
Rotating tool panel	.38
Rubber mats	.53, 55, 59, 63, 65, 73, 100, 101
Service trolleys	.73
Shelf dividers	.78
Shelf for cabinet version	.100
Shelves	.35, 100
Side light 500	.33
Sliding door cabinets	.42, 60, 100
Sliding piece/tool carrier	.33, 101
Sliding rails	.100
Small storage cabinets	.42
Sovella R-hooks	.90
Sovella wall shelving	.96
Base section	.97
Extension section	.97
Oval horizontal rail	.98
Upright profiles	.98
Brackets	.98
Shelves	.99
Stainless steel shelving system	.99
Cupboard fixing brackets	.99
Perforated back panels	.99
Spacer bar Workshop	.20
Spare parts	.100
Spiral cord	.40
Stand for plastic containers	.38
Steel shelves	.35
Storage System	.76
Standard parts	.76
Extension parts	.76
Storage System combinations	.77
Storage system components	.78
Drawers and interior combinations	.78
Shelf dividers	.78
Shelves	.78
Storage trolley	.67
Suspension rails	.39
Suspension rails with arm	.38
Swivel wheels	.101

	page
Table frames	
Basic worktable frame	.16
Basic corner table frame	.16
Basic extension table frame	.16
Basic upright frame	.15, 16
Concept worktable frame	.12
Concept corner table frame	.12
Concept extension table frame	.12
TowerLine worktable frame	.24
TowerLine corner table frame	.24
TowerLine extension frame	.24
Table tops	
Table tops	.13, 17
Workshop table tops	.21
Workshop steel top	.21
Workshop top with plastic edges	.21
Workshop top with steel edges	.21
Workshop wooden top	.21
TowerLine table tops	.25
Tables	.8
Task light	.33
T-foot	.89
Tilting frame	.13
Tool balancers	.33
Tool brackets	.42, 60
Tool cabinet, small	.41
Tool panel	.38
Tool storage system	.89
Top covers	.100
TowerLine accessories	.25
TowerLine corner table frame	.24
TowerLine corner shelf	.24
TowerLine extension frame	.24
TowerLine single-sided workstation	.23
TowerLine steel shelves	.24
TowerLine table colour stripe pair	.25
TowerLine table tops	.25
TowerLine double-sided workstation	.23
TowerLine workstation	.23
TowerLine workstation for teamwork	.23
TowerLine worktables	.22
TowerLine worktable frame	.24
Transport skate	.13
Trolley spare parts	.101
Trolleys	.66
Worktop trolley	.68
Storage trolley	.68
Ergo trolley	.68
Multi trolley	.68
Heavy-duty trolleys	.70
Fitter's trolleys	.71
Basic trolleys	.72
Service trolleys	.73
TWIN set, drawer unit 55 comb	.54
Upper shelves	.36
Backstops for the upper shelves	.36
Upright tube modules	.31
Upright tubes	.31
Warranty	.7
Wheel sets	
Wheel sets for chairs	.45
Wheel sets for drawer units	.100
Wheel sets for transport skate	.101
Wheel sets for trolleys	.101
Wooden chairs and stools	.45
Workshop installation workstation	.19
Workshop legs	.20
Workshop standard worktable	.19
Workshop steel top	.21
Workshop table tops	.21
Workshop top with plastic edges	.21
Workshop top with steel edges	.21
Workshop worktables	.18
Workshop repair workstation	.19
Workshop workstation	.19
Worktables	.8
Worktop trolley	.67, 68
Wristband junction box	.40

Long and successful history and global network

Sovella has a long history in industrial furniture design and manufacture, and well over two decades of experience in ergonomic workspace development. Our design and manufacturing facilities are located in Finland.

Thanks to our global sales network, you can receive local support and customer service anywhere in the world. We have offices in Europe, North America, and Asia as well as an extensive network of selected dealers in more than 20 countries.



2007	Sovella Group becomes the new name of the company.
2006	Sovella® brand covers all the products of GWS Systems.
2004	GWS Systems becomes an independent company.
1990s	The international dealer network is expanded and the US subsidiary established. GWS Systems is created to regroup the industrial furniture division of GWS Group.
1980s	The pioneer in ergonomic workstations, System GWS is launched. It becomes an international success, and the company enlarges its activity to Europe.
1970s	The new TK-75 industrial furniture system was introduced.
1960s	Sovella brand name was established for the first time.
1950s	Manufacture of industrial furniture begins.
1876	GWS was founded.

Sovella Group, PO Box 33, FI-40351 Jyväskylä, Finland. Tel +358 10 446 911, fax +358 10 4469 290, marketing@sovella.com

BENELUX

GWS Systems Oy
Mechelaarstraat 17,
NL-4903 RE Oosterhout NB
Tel. +31 162 454 383
Fax +31 162 434 712
infoben@sovella.com
www.sovella.com

FRANCE

Sovella SARL
Z.A.C. de la Bonne Rencontre
1, voie Gallo Romaine, Quincy-Voisins
F-77334 MEAUX CEDEX
Tel. +33 1 64 17 11 11
Fax +33 1 64 17 11 10
infofr@sovella.com
www.sovella.fr

UNITED KINGDOM

Sovella Oy
PO Box 845
Horsham
GB-West Sussex RH12 9FW
Tel. +44 1403 276 445
Fax +44 1403 276 434
infouk@sovella.com
www.sovella.com

CHINA

Sovella Shanghai Representative Office
Room 2201, Shen Xin Plaza,
No. 200 East Ning Hai Road,
Shanghai 200021
Tel. +86 21 6247 1808
Fax +86 21 6247 1838
saleschina@sovella.com
www.sovella.com

GERMANY

Sovella GmbH
Frankfurter Straße 101
D-65479 Raunheim
Tel. +49 6142 992 50
Fax +49 6142 218 75
infode@sovella.com
www.sovella.de

USA

Sovella, Inc.
1910-C Cobb International Blvd.
Kennesaw, GA 30152
Tel. +1 770 424 0004
Tel. +1 800 437 6772
Fax +1 770 424 8066
infousa@sovella.com
www.sovella.us

FINLAND

Sovella Oy
PO Box 33
FI-40351 Jyväskylä
Tel +358 10 4469 350
Fax +358 10 4469 290
marketing@sovella.com
www.sovella.fi

SWEDEN

Sovella AB
Knarrarnäsgatan 15
SE-16440 Kista
Tel. +46 8 625 76 80
Fax +46 8 625 76 78
infose@sovella.com
www.sovella.se

You can find our local sales agencies in various countries at www.sovella.com

Discover the human side of work!

Sovella®
WWW.SOVELLA.COM